

FRENCH FITNESS

X9

FUNCTIONAL MULTI GYM SYSTEM

ASSEMBLY MANUAL

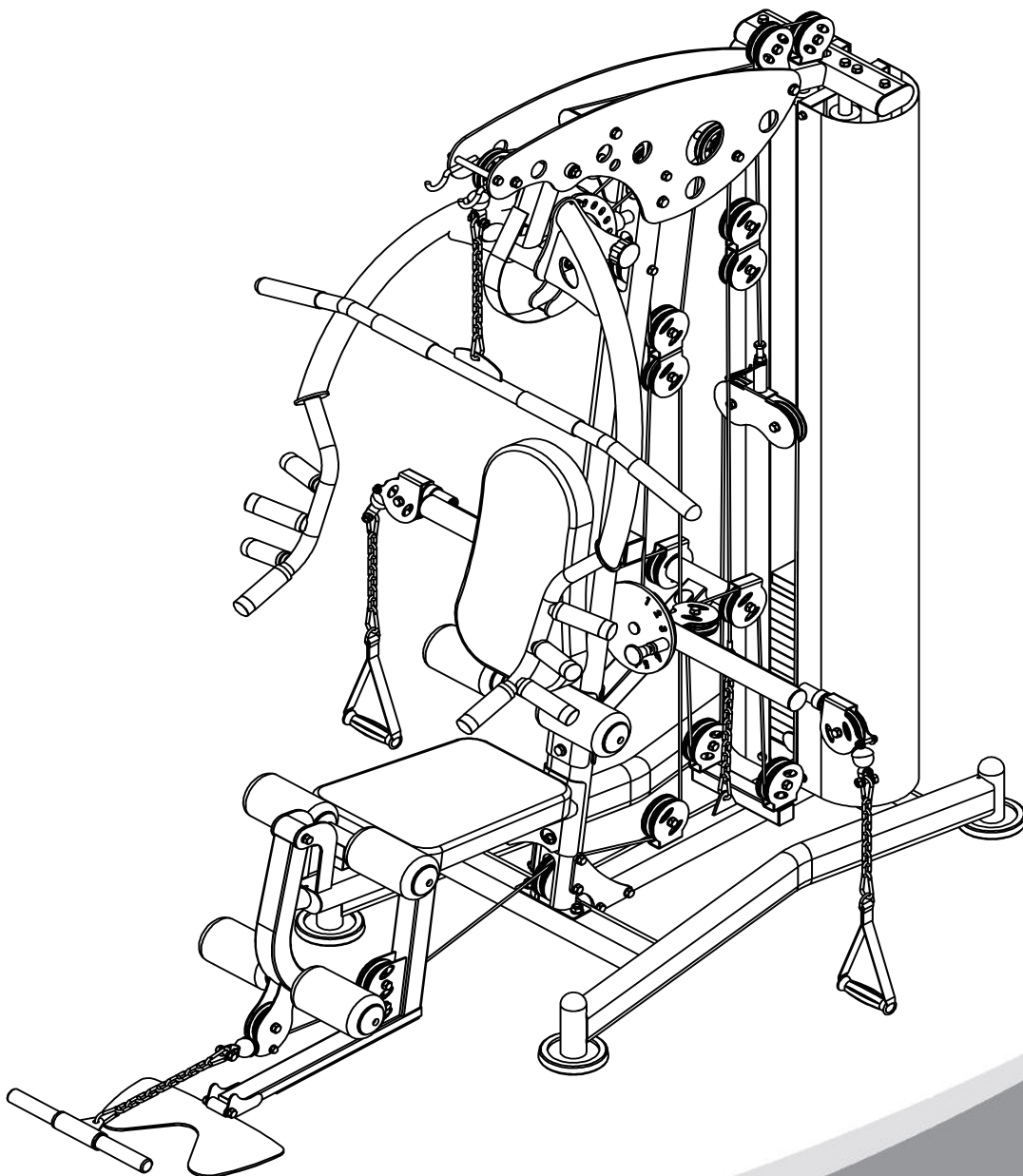

FEATURES

- Heavy duty steel construction
- Thick pads with extra support and cushioning
- Space saving design
- Adjustable seat height and back rest to perform various exercises with ease
- Reinforced nylon pulley's with precision machined steel ball bearings
- Optional Leg Press Attachment
- Functional Training Arms

TECH SPECS

- 190 lb Weight Stack
- Lat Pulldown: Feels like 280 lbs Due to pulley ratio
- Dimensions: 82"D x 52"W x 83.9"H

WARRANTY

- Lifetime Parts and 1 Year Labor Warranty

Parts Diagram

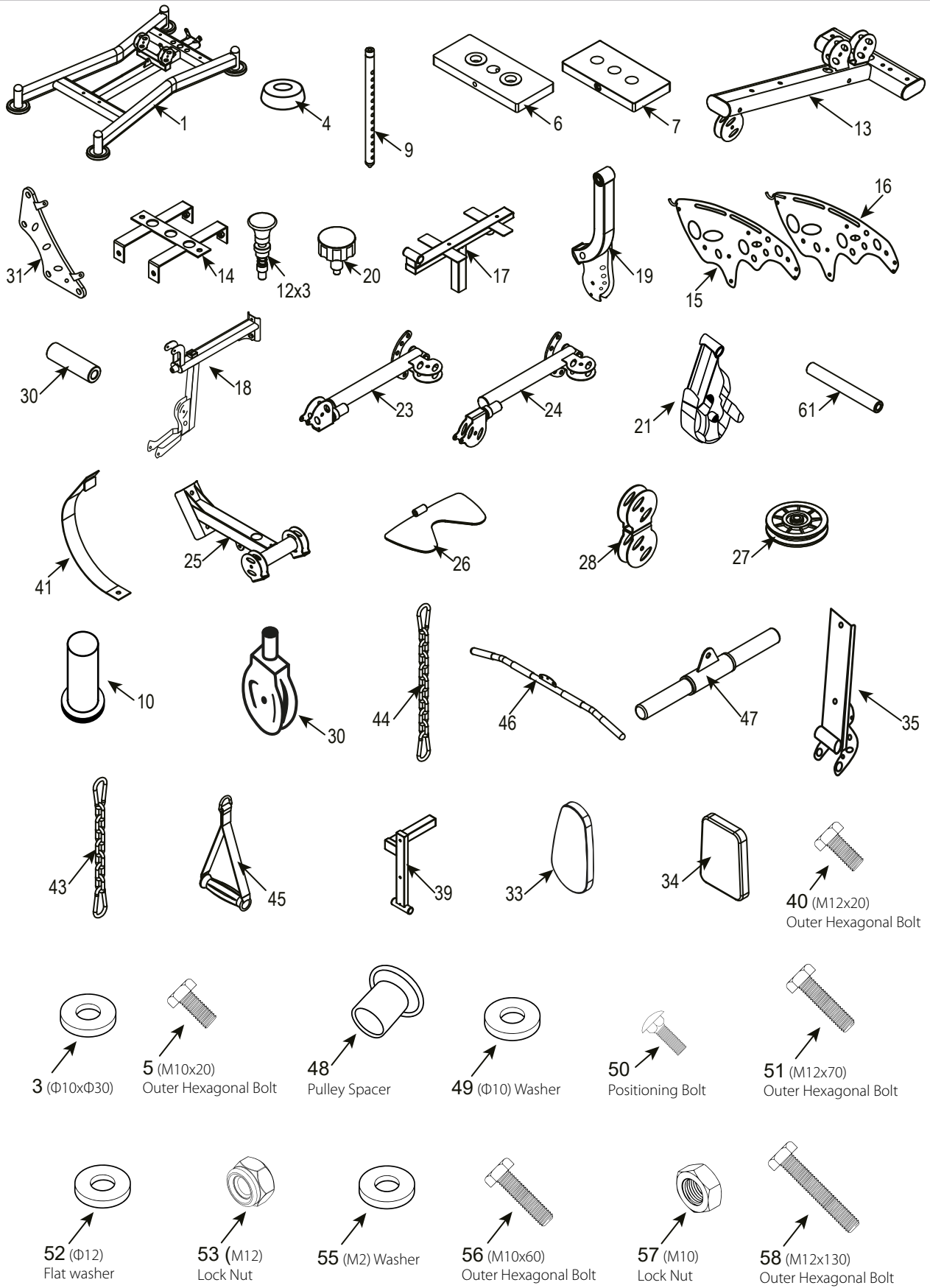

Parts Diagram

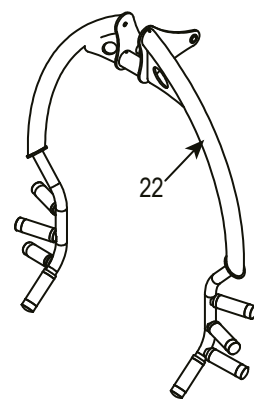
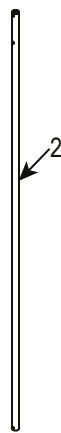
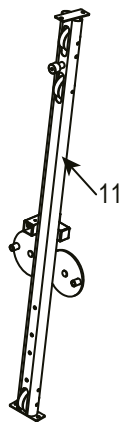
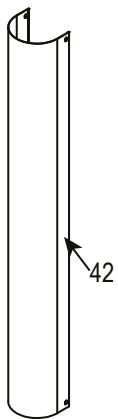
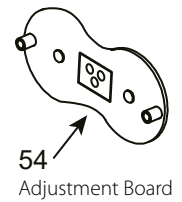
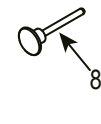
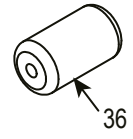
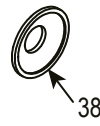
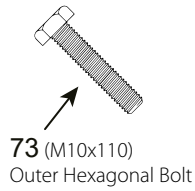
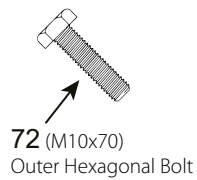
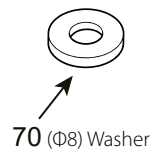
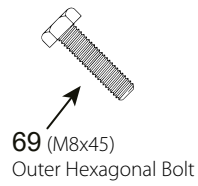
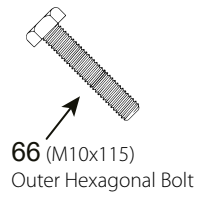
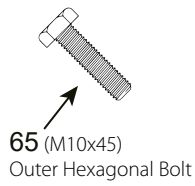
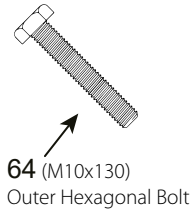
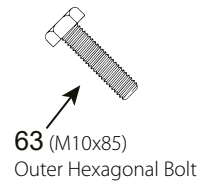
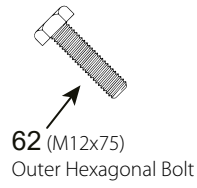
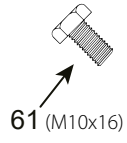
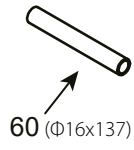
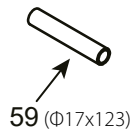

CLEAN GUIDE RODS

Step must be completed prior to installing. Failure to do so can leave residue from packaging and other sources stuck in the bushings.

Guide rods need to make sure they are cleaned prior to installation otherwise this will cause the top plate to get stuck. It causes buildup in the bushings of the top plates. They just need to be cleaned out as well as the guide rods.

Use Silicon Spray and fiber to remove any excess residue. These can be found around the house or at a nearby hardware store, pics below. Use silicon Spray and steel wool.

We use "B'laster 16-SL Industrial Strength Silicone Lubricant" and Steel Wool, Grade #0000 Super Fine Grade

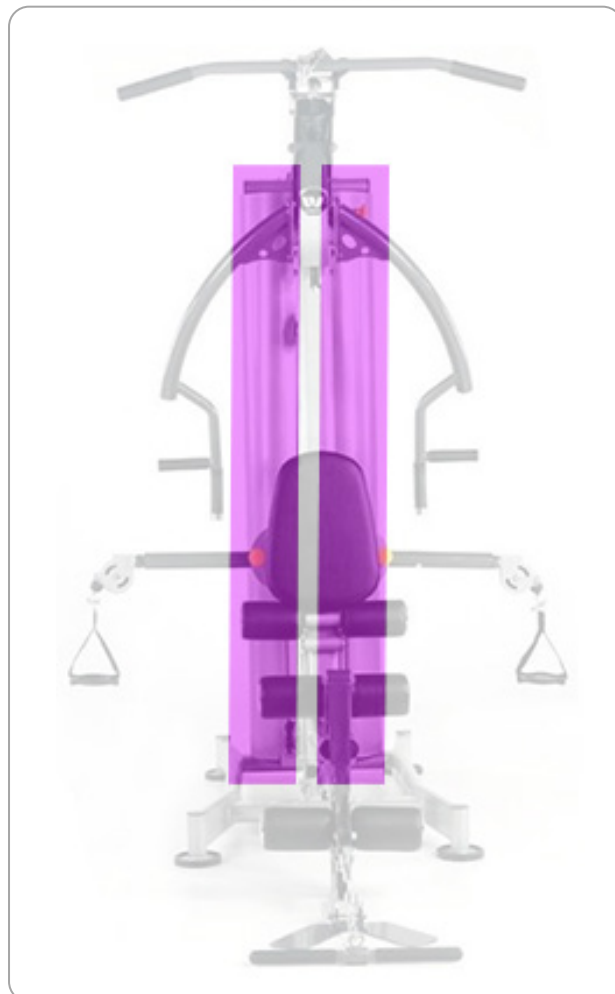

Installing Step 1 Exploded View

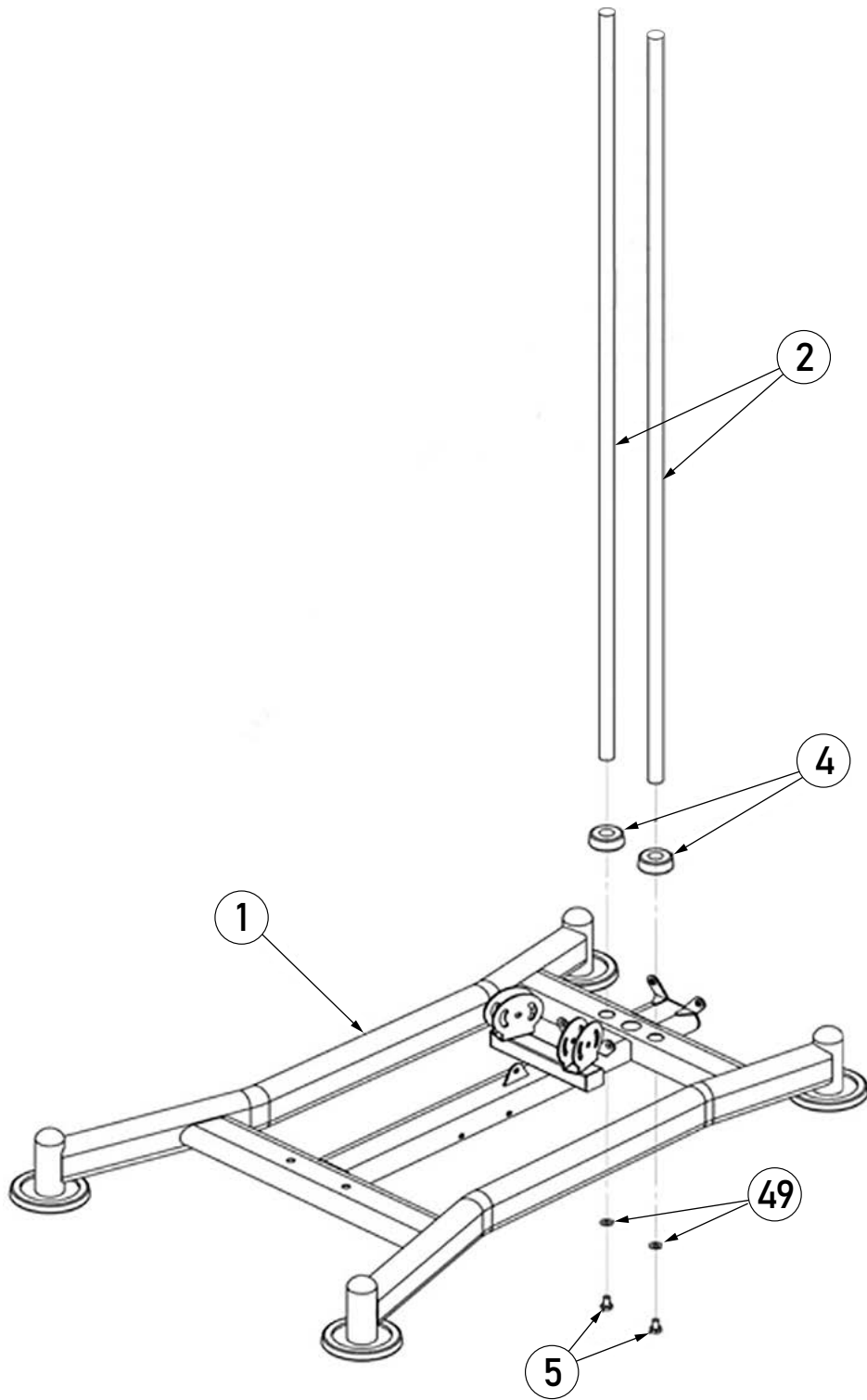

Installing Step 1 After Installation

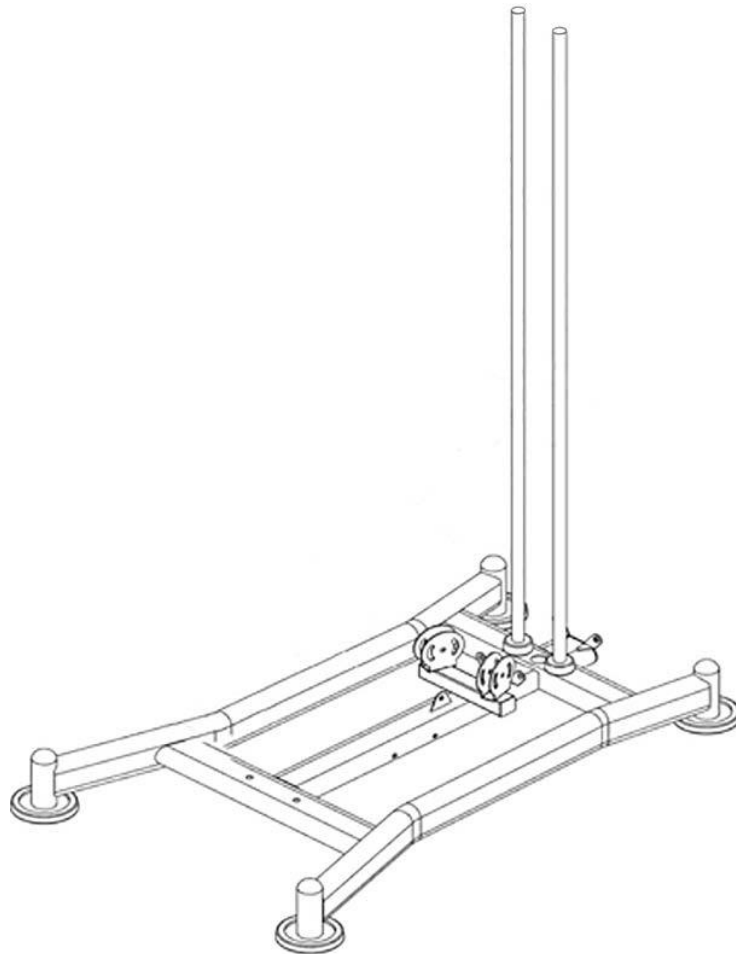

Installation Instruction

1. Put $\Phi 10$ washer (49) over M10*20 outer hexagonal bolts (5), and fasten the guiding rod assembly (2) to the under frame weldment (1).
2. Install the cushion (4) on the guiding rod assembly (2).

Installing Step 2 Exploded View

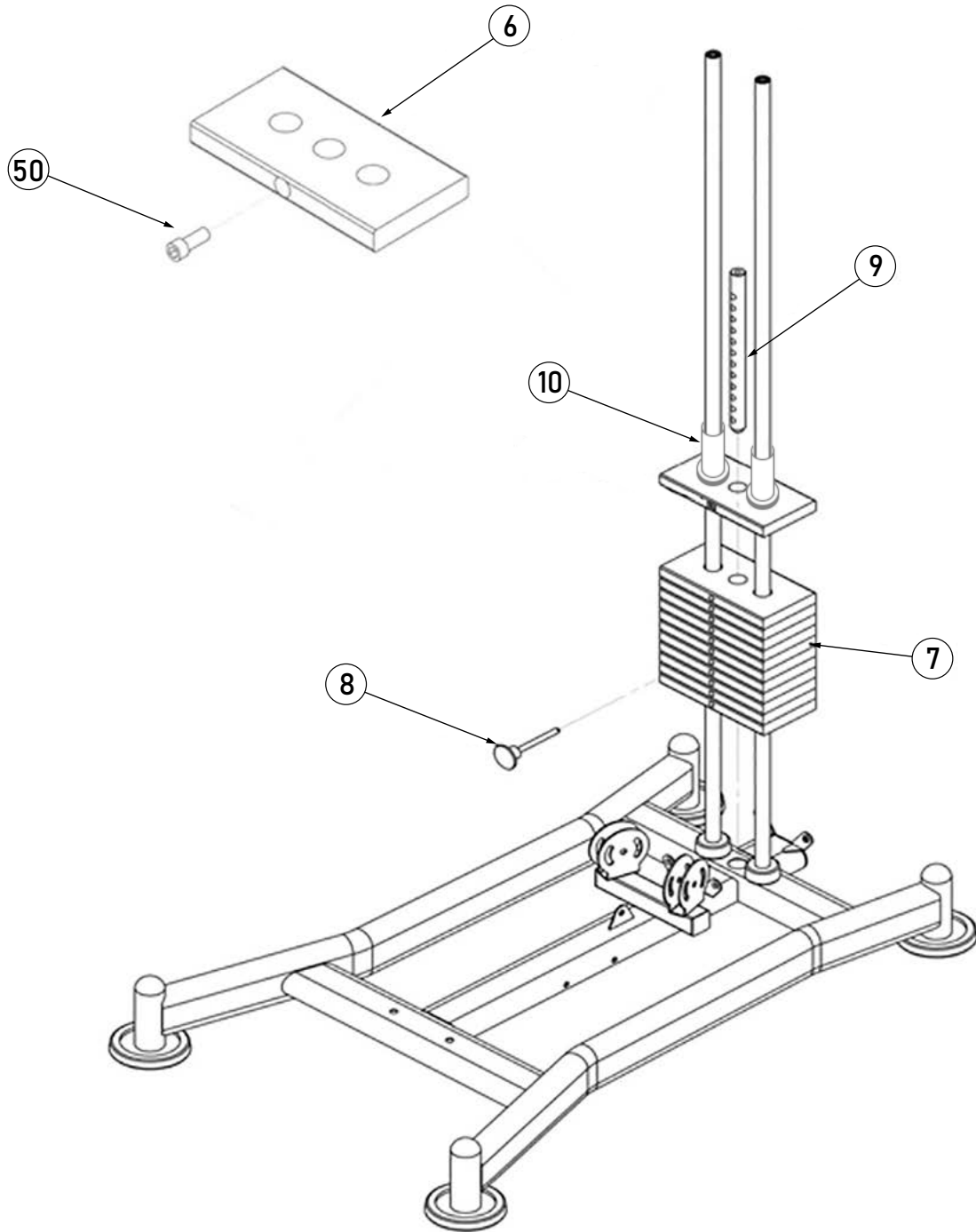

Installing Step 2 After Installation

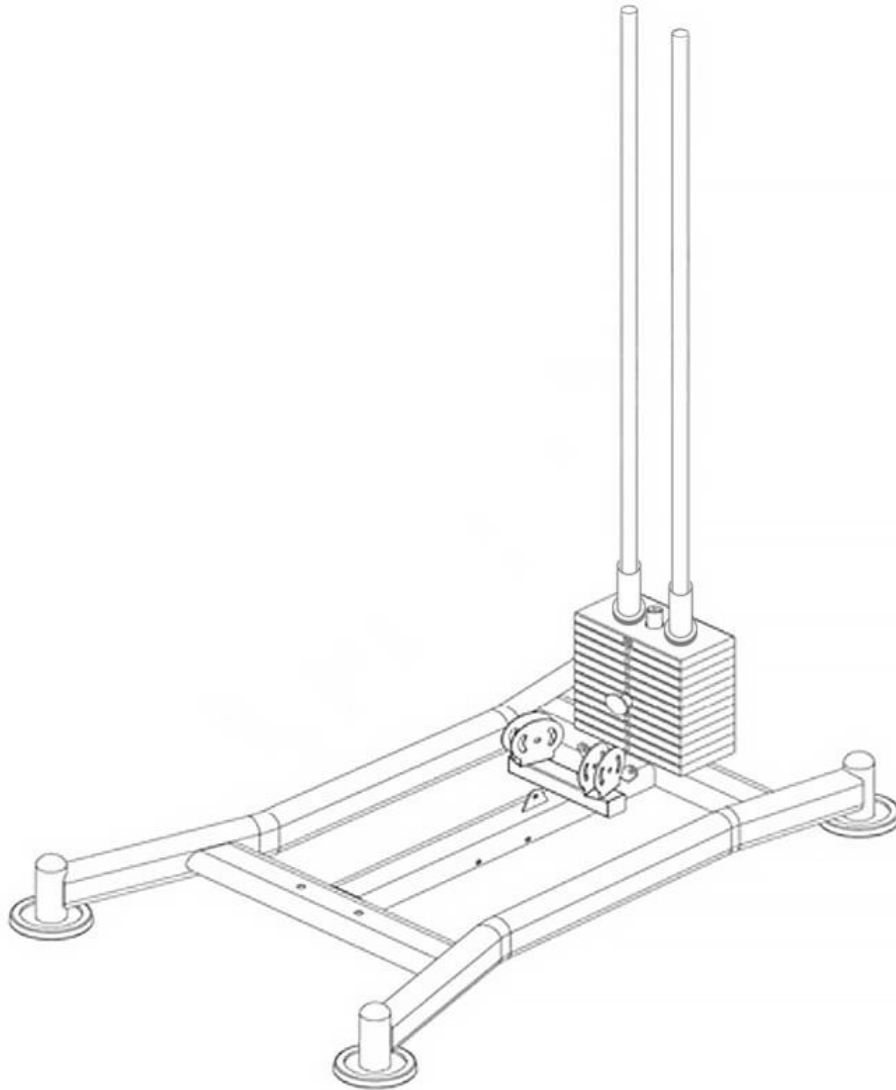

Installation Instruction

1. Place 11 PCS cast iron counterweight lower piece (7) and cast iron counterweight top piece (6) in sequence on the upper end of the guiding rod assembly (2).
2. Place bushing (10) into cast iron counterweight top piece (6).
3. Insert the lifting rod (9) and the cast iron counterweight lower piece (7) and the cast iron counterweight top piece (6) together, and install the positioning bolts (50) on the cast iron counterweight top piece (6).
4. Insert the magnetic pin (8) on the cast iron counterweight lower piece (7) and the lifting rod (9).

Note: The outer hexagonal bolts need to be tightened.

Installing Step 3 Exploded View

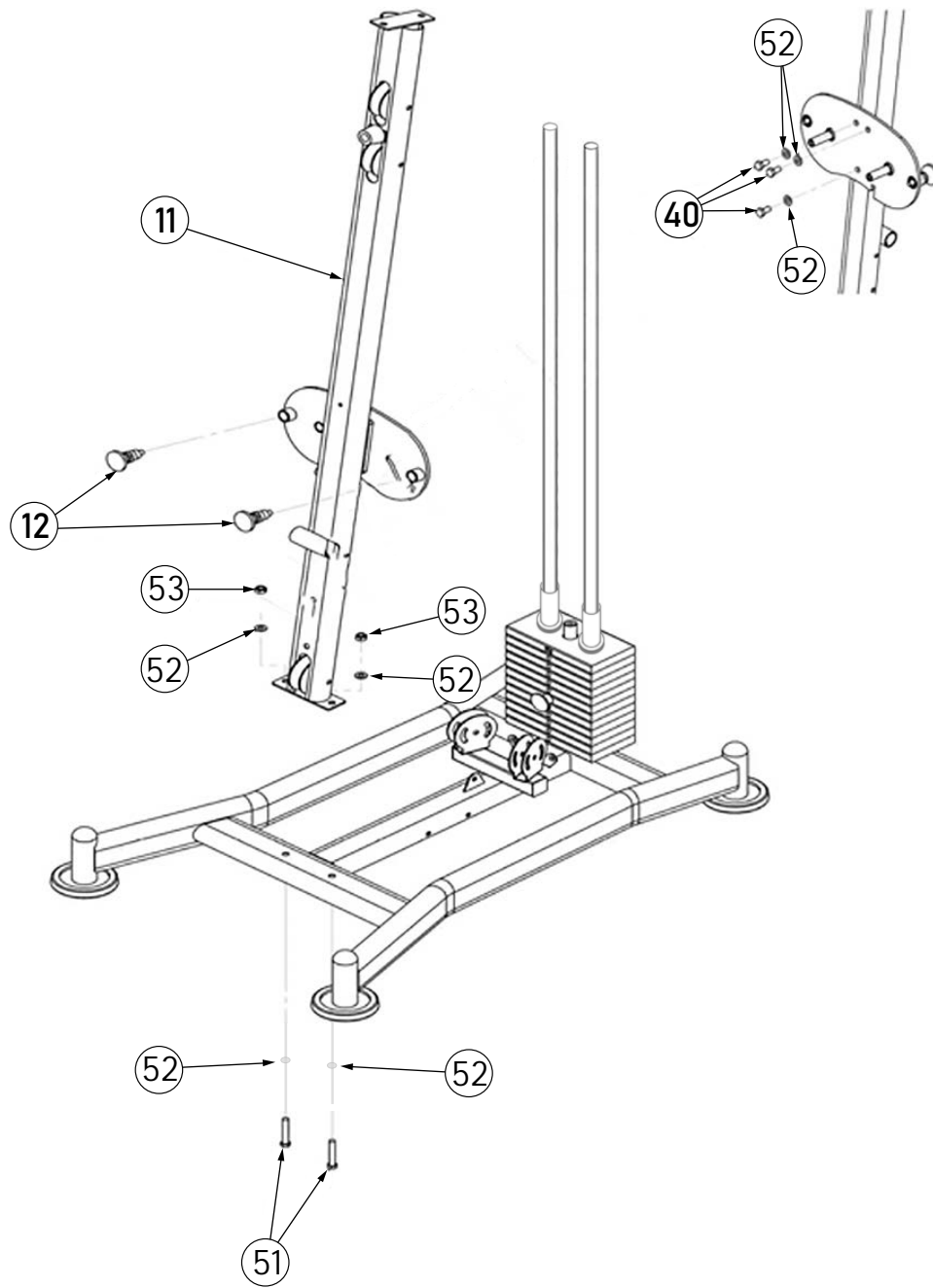

Installing Step 3 After Installation

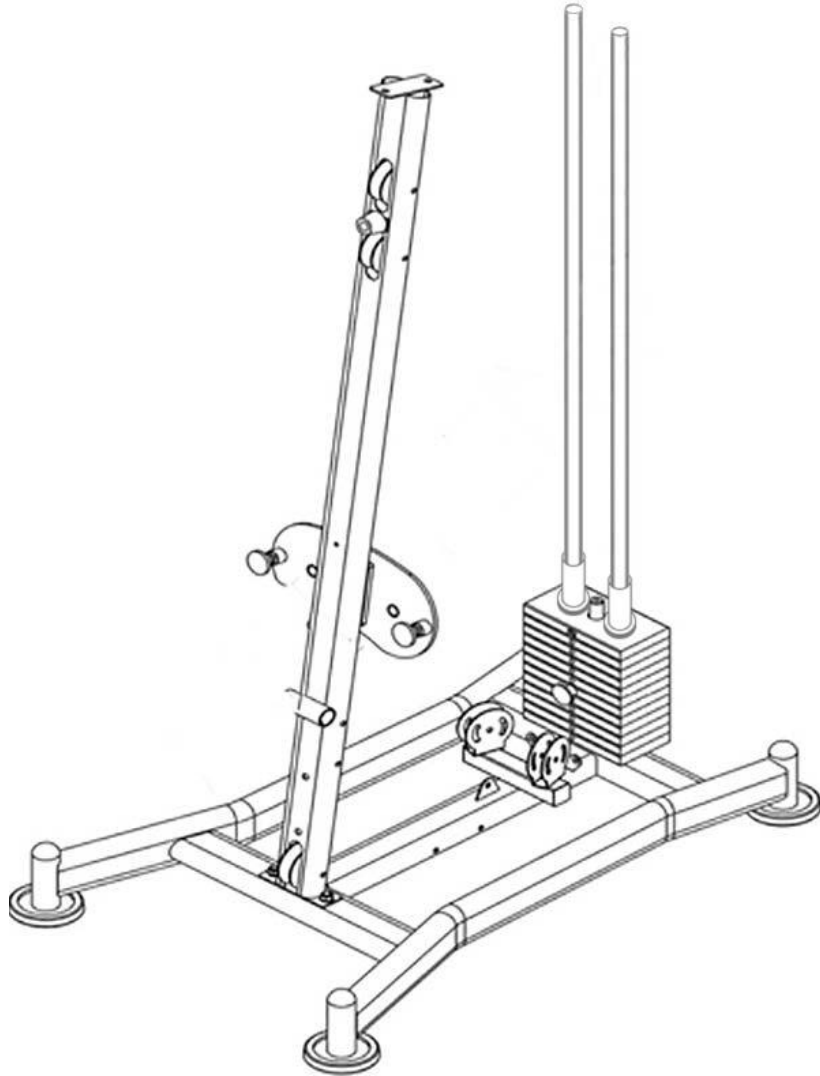

Installation Instruction

1. Fasten the inclined support beam (12) to the chassis assembly with M12*70 outer hexagonal bolts (51), Φ 12 flat washers (52), and M12 lock nuts (53).
2. Use M12*20 outer hexagonal bolts (40) and Φ 12 flat washers (52) to fix the inclined support beam adjustment board (54).

Note: The outer hexagonal bolts need to be tightened.

Installing Step 4 Exploded View

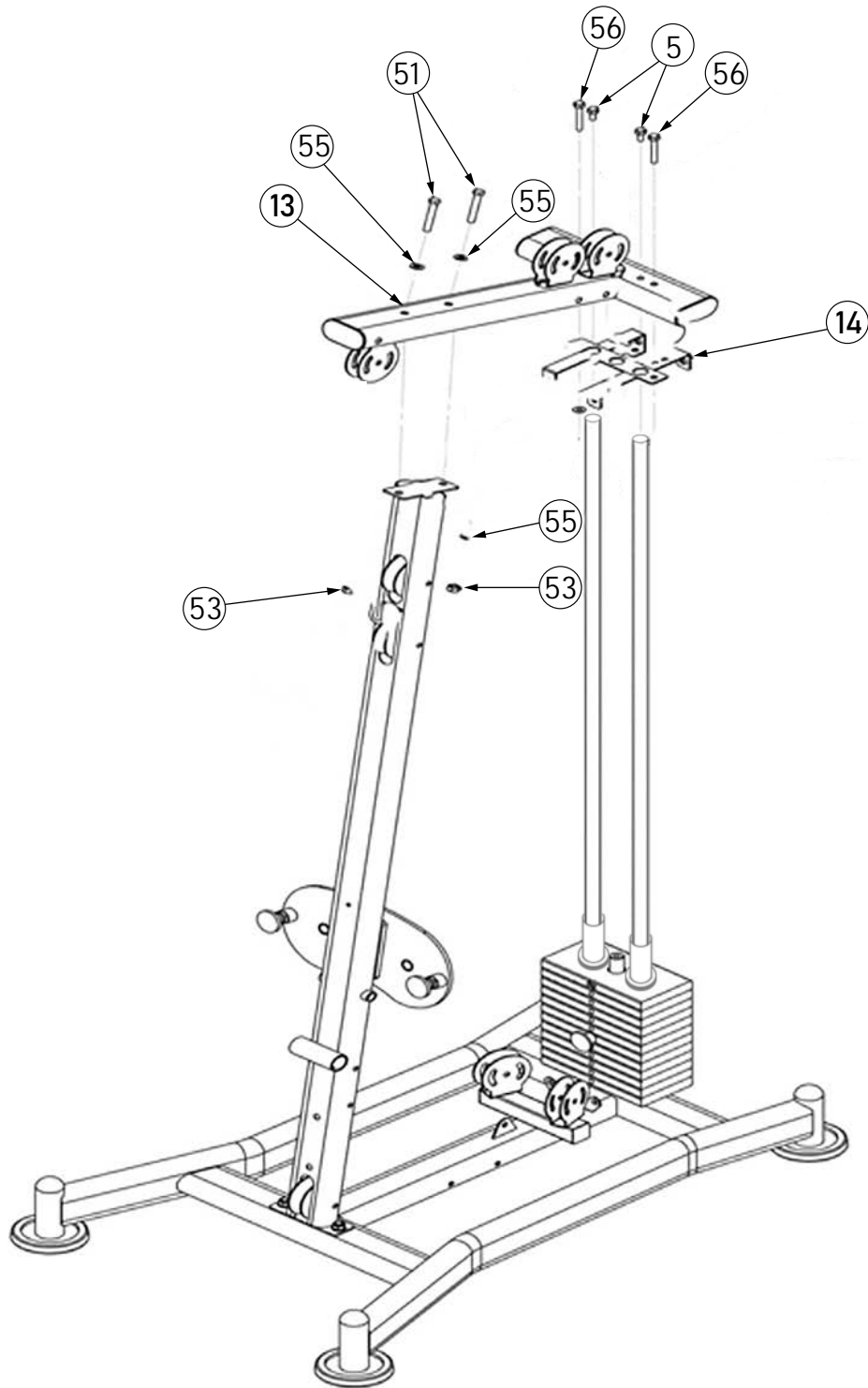

Installing Step 4 After Installation

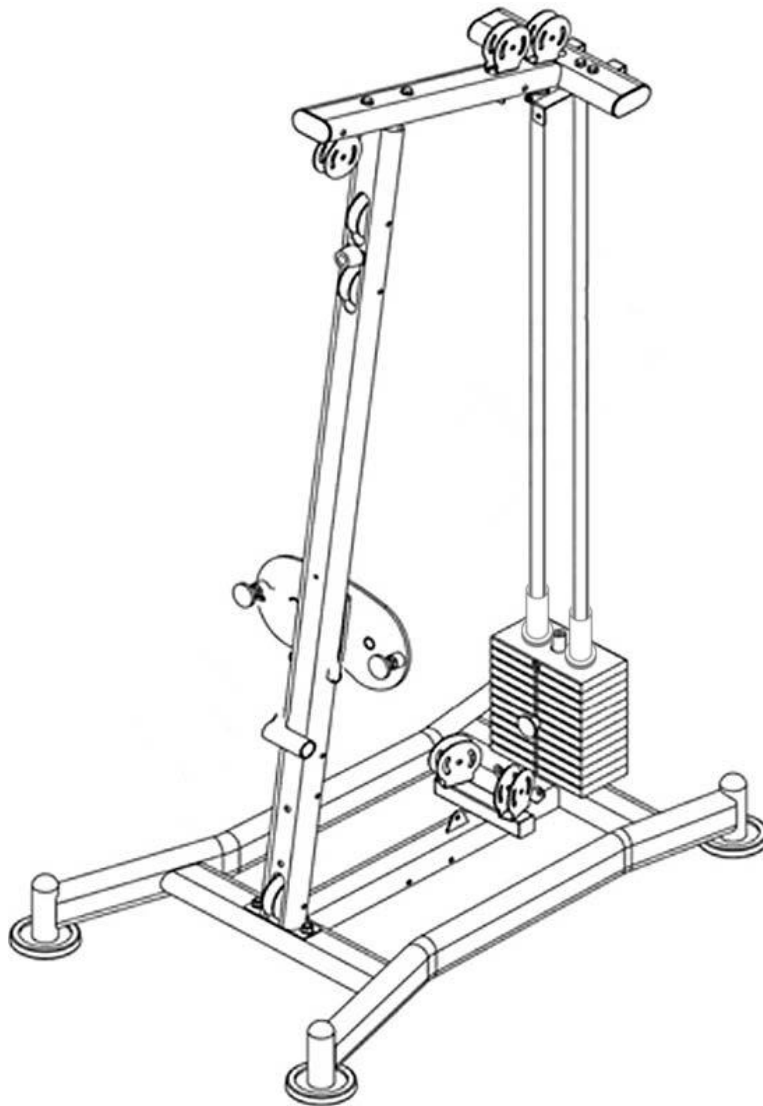

Installation Instruction

1. Fix the shield support frame (14) and the upper beam (13) together with M10*60 outer hexagonal bolts (56), $\Phi 10$ washers (49) and M10 lock nuts (57).
2. Connect the upper beam (13) and the guiding rod (2) together, and fasten them with M10*20 outer hexagonal bolts (5), $\Phi 10$ washers (49) M10 lock nuts (57).
3. Fasten the upper beam (13) to the inclined support beam (11) with M12*70 outer hexagonal bolts (51), M2 washers (55), and M12 lock nuts (53).

Note: The outer hexagonal bolts need to be tightened.

Installing Step 5 Exploded View

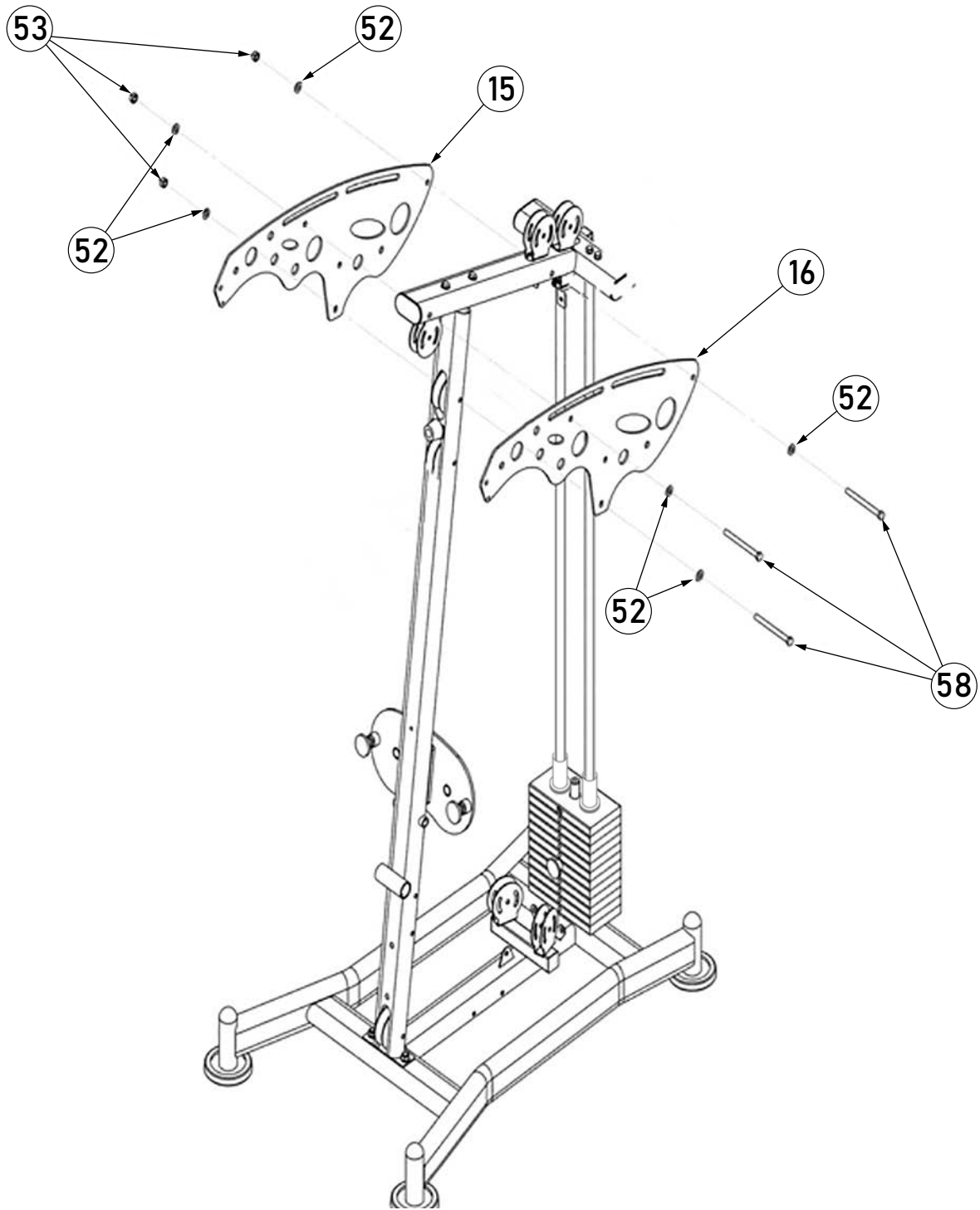

Installing Step 5 After Installation

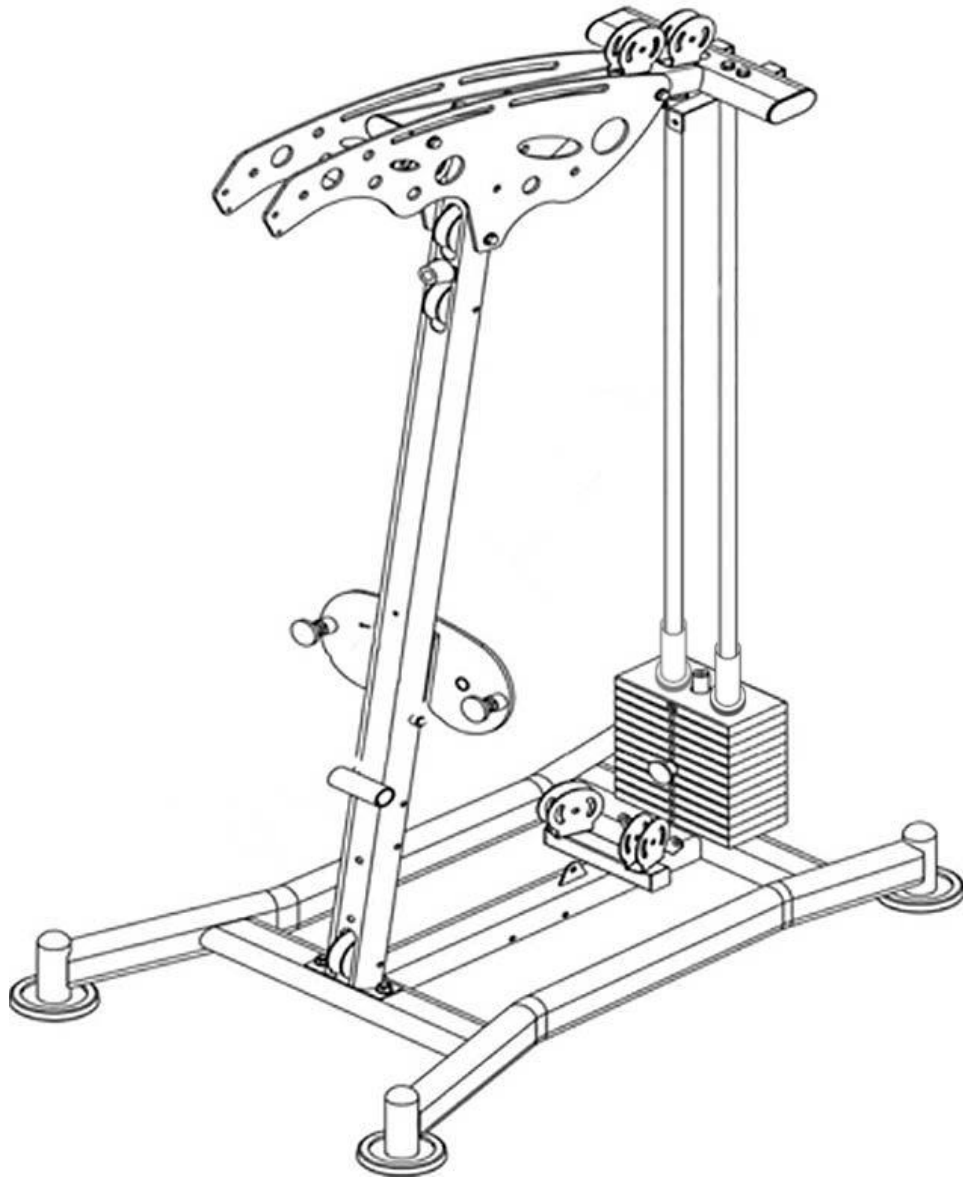

Installation Instruction

1. Use M12*130 outer hexagonal bolts (58), Φ 12 washers (52) and M12 lock nuts (53) to fasten the decorative boards (15, 16) to the upper beam and the inclined support beam assembly.

Note: The outer hexagonal bolts need to be tightened.

Installing Step 6 Exploded View

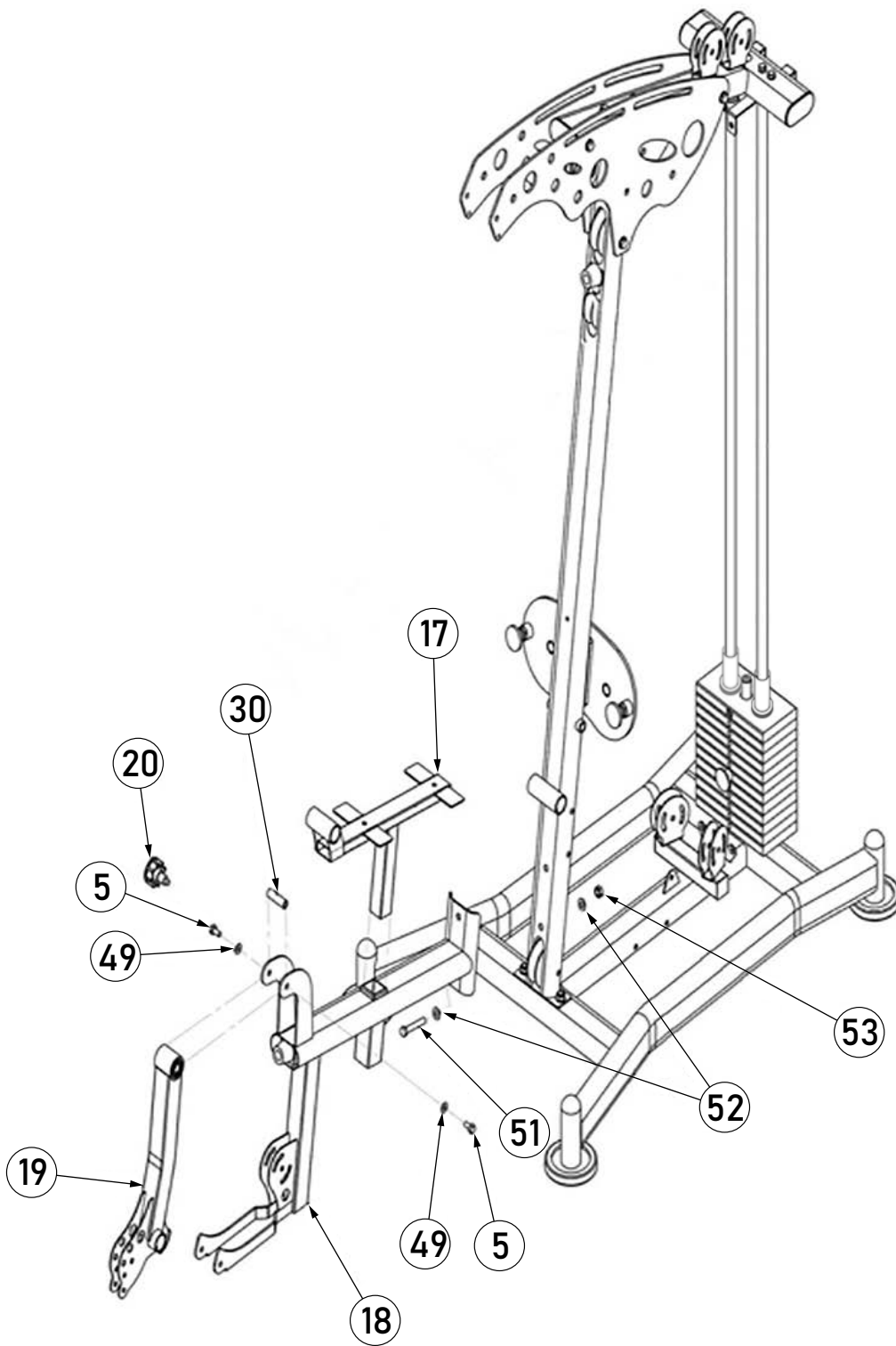

Installing Step 6 After Installation

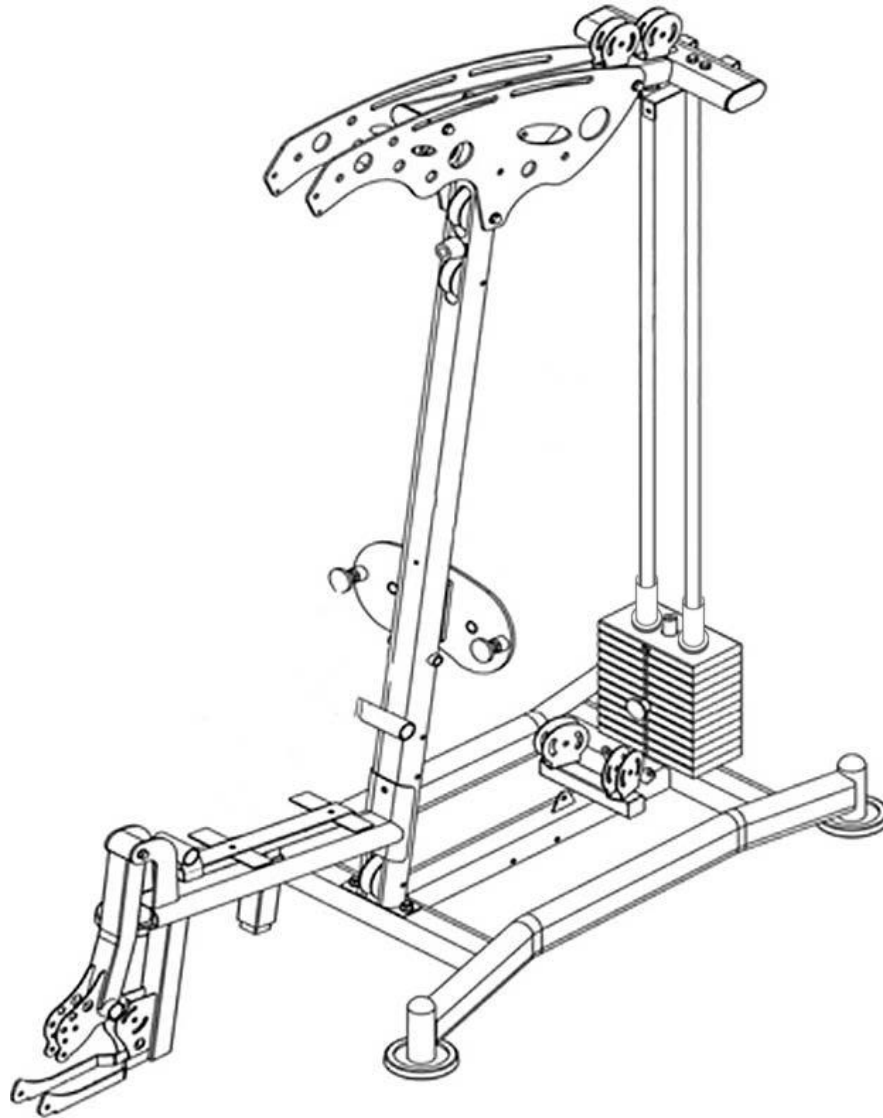

Installation Instruction

1. Use M12*70 outer hexagonal bolts (51), Φ 12 washers (52) and M12 lock nuts (53) to fasten the seat support in tube assembly (18) to the lower hole of the inclined support beam.
2. Install the kick rotation shaft (30) on the foot hook bending tube (31), and then connect the foot hook bending tube (19) and the seat supporting tube assembly (18) together, and fasten them on both ends of the kicking shaft (30) using M10*20 outer hexagonal bolts (5) and Φ 10 washers (49).
3. Install the seat cushion adjustment tube (17) on the seat supporting tube (18) and tighten it with a hexagonal reset pull pin (20).

Note: The outer hexagonal bolts need to be tightened.

Installing Step 7 Exploded View

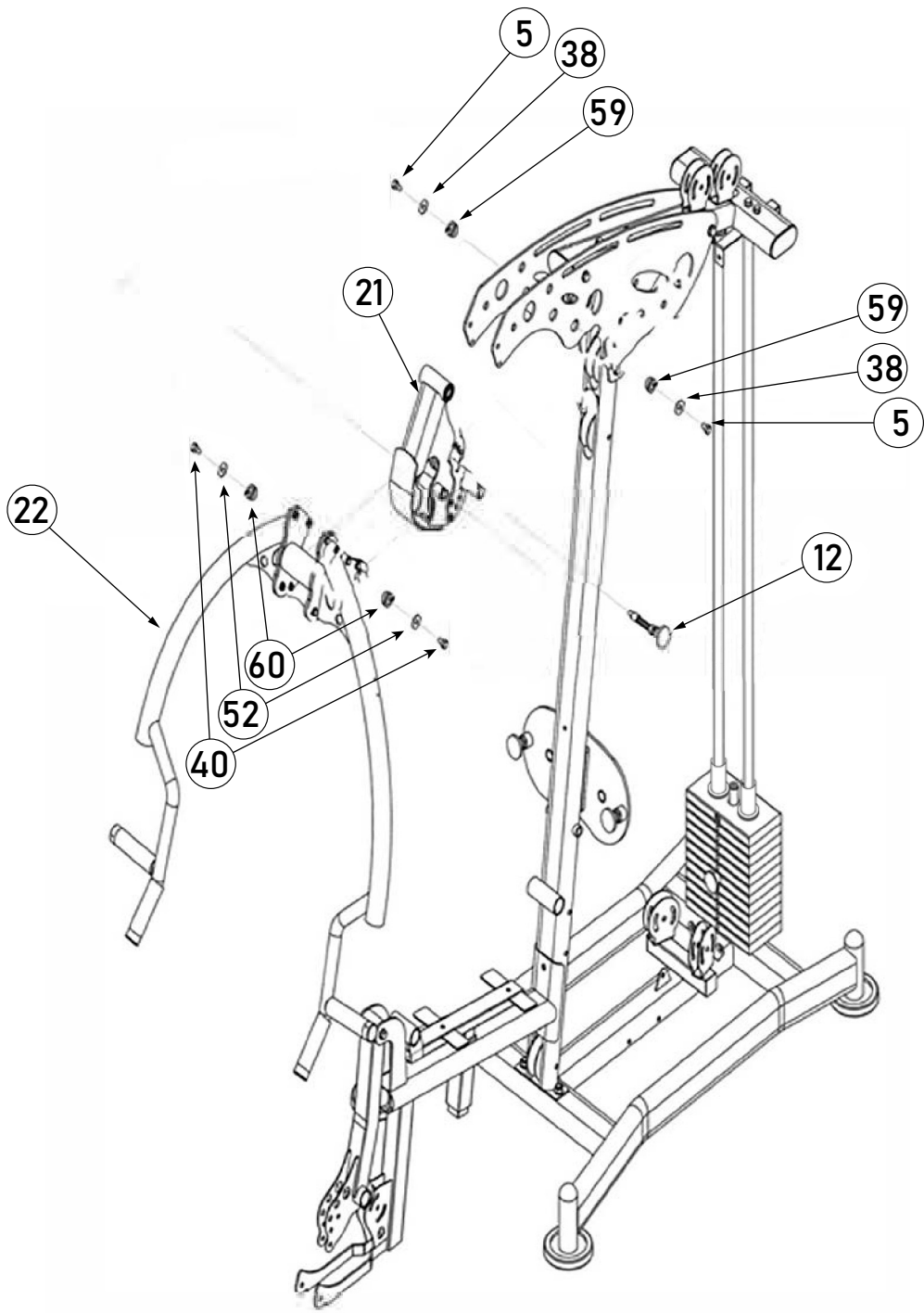

Installing Step 7 After Installation

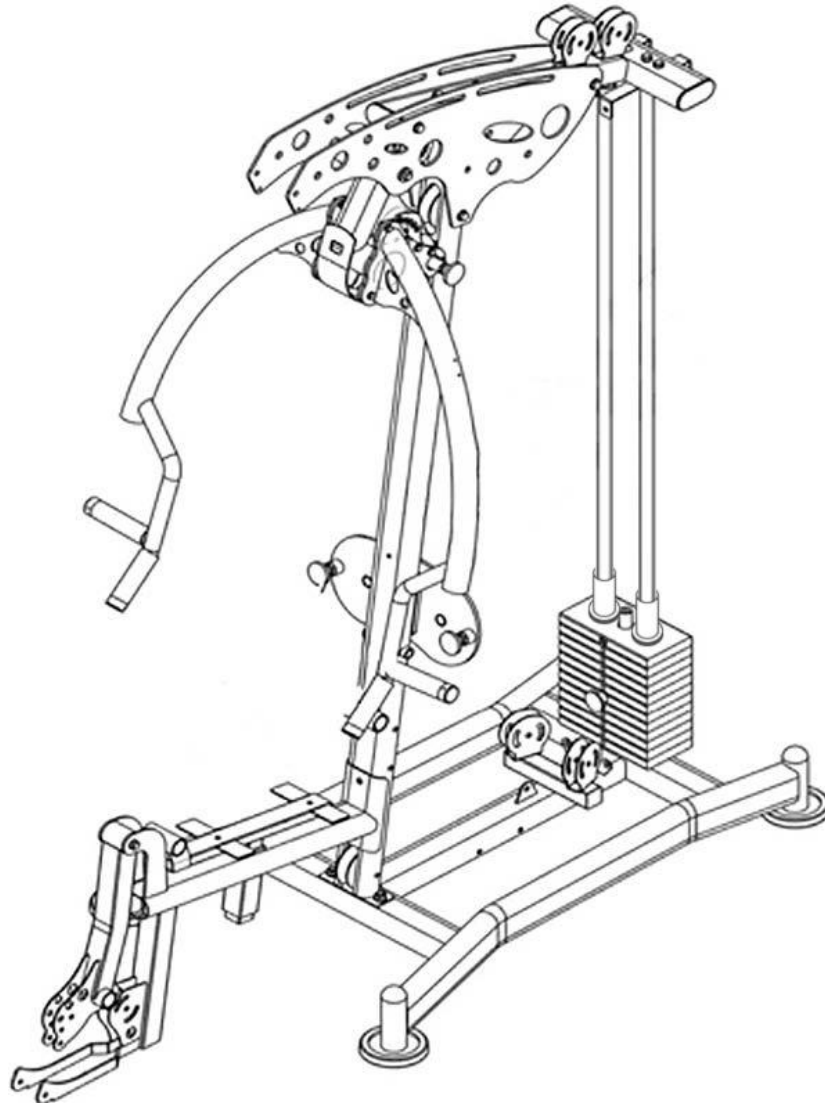

Installation Instruction

1. Use the $\Phi 17 \times 123$ front pushing frame shaft (59) to connect the front pushing frame (21) and the decorative boards (15, 16) together, and fasten it to both ends of the front pushing frame shaft (21) with M10*20 outer hexagonal bolts (5) and $\Phi 10 \times \Phi 30$ washers (3).
2. Connect the front pushing arm (22) and the front pushing frame (21) together with the $\Phi 16 \times 137$ front pushing arm connection shaft (60), and fasten it on both ends of the front pushing arm connection shaft (22) with M12 *20 outer hexagonal bolts (40) and $\Phi 12$ flat washers (52).
3. Connect the reset pull pin (12) and the front pushing frame (21) together .

Note: The outer hexagonal bolts need to be tightened.

Installing Step 8 Exploded View

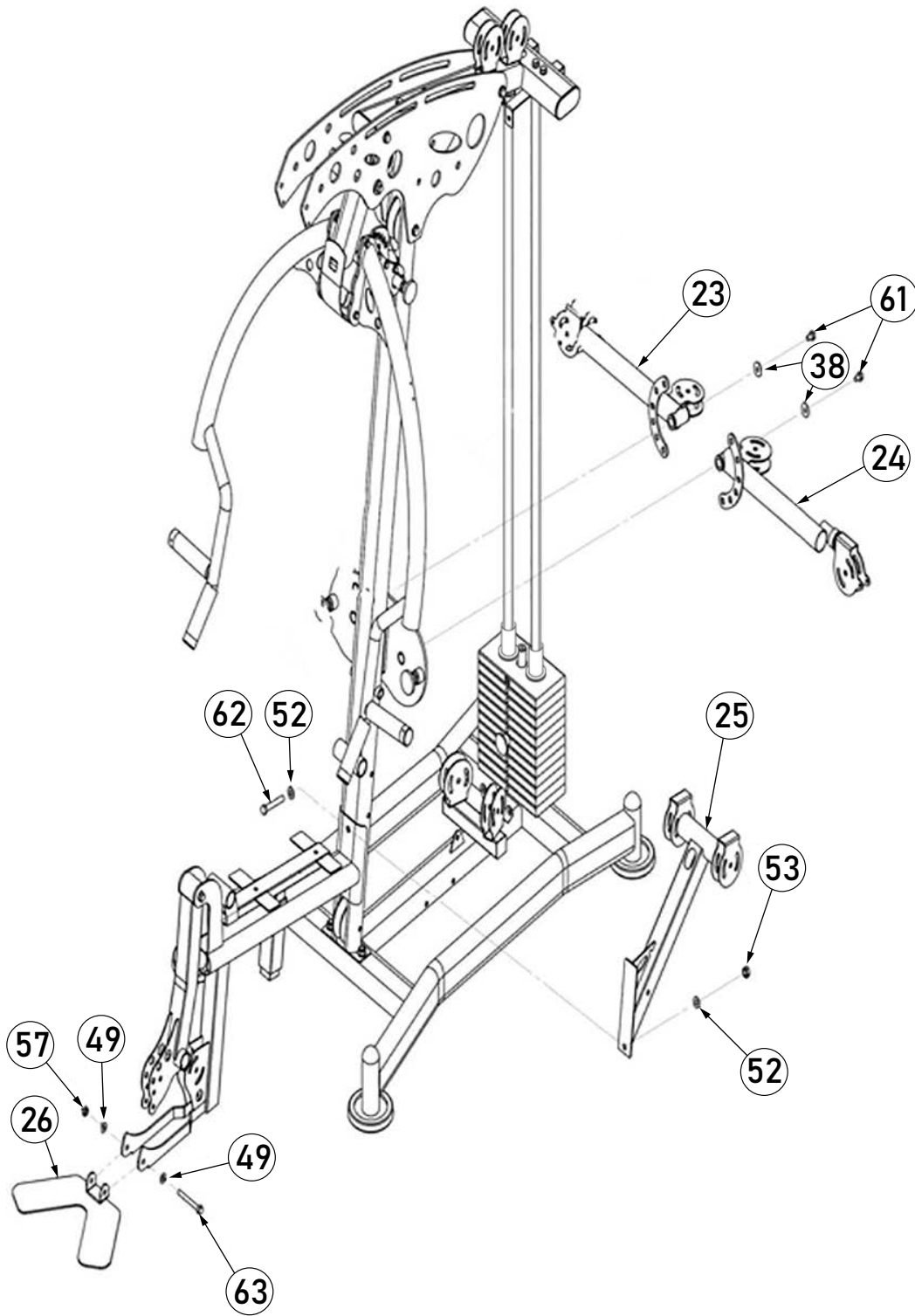

Installing Step 8 After Installation

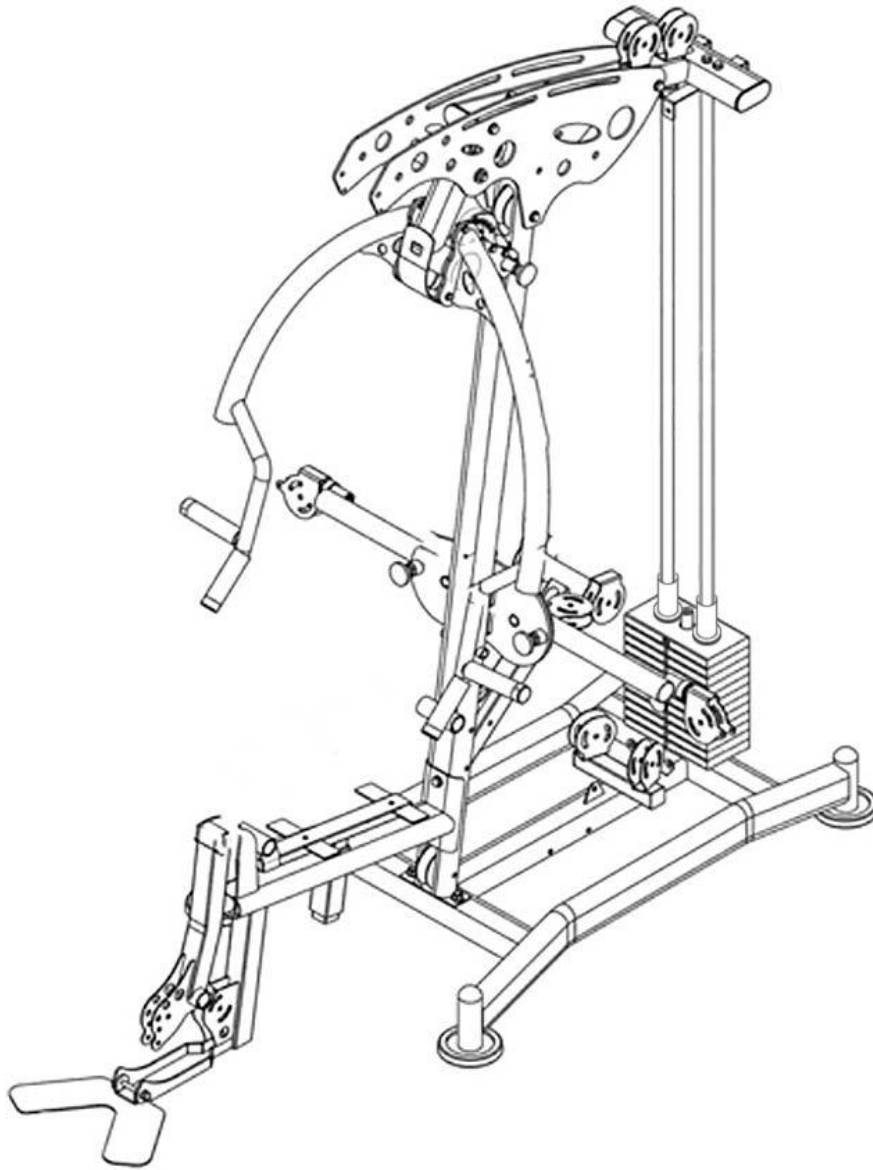

Installation Instruction

1. Fasten the butterfly arm-left (24) to the butterfly arm fixing board of the inclined support beam with M10*16 outer hexagonal bolts (61) and $\Phi 10*\Phi 30$ washers (3).
2. Fasten the butterfly arm-right (23) to the butterfly arm fixing board of the inclined support beam with M10*16 outer hexagonal bolts (61) and $\Phi 10*\Phi 30$ washers (3).
3. Pass the M12*75 outer hexagonal bolts (62) and $\Phi 12$ washer (52) through the inclined support beam and the inclined support pulley frame(25), and fasten the other end to the M12*75 outer hexagonal bolts (62) with M12 lock nut (53) and $\Phi 12$ washer (52).
4. Use M10*85 outer hexagonal bolts (63), $\Phi 10$ washers (49) and M10 lock nuts (57) to fasten the pedal board (26) on the seat supporting tube assembly.

Note: The outer hexagonal bolts need to be tightened.

Installing Step 9 Exploded View

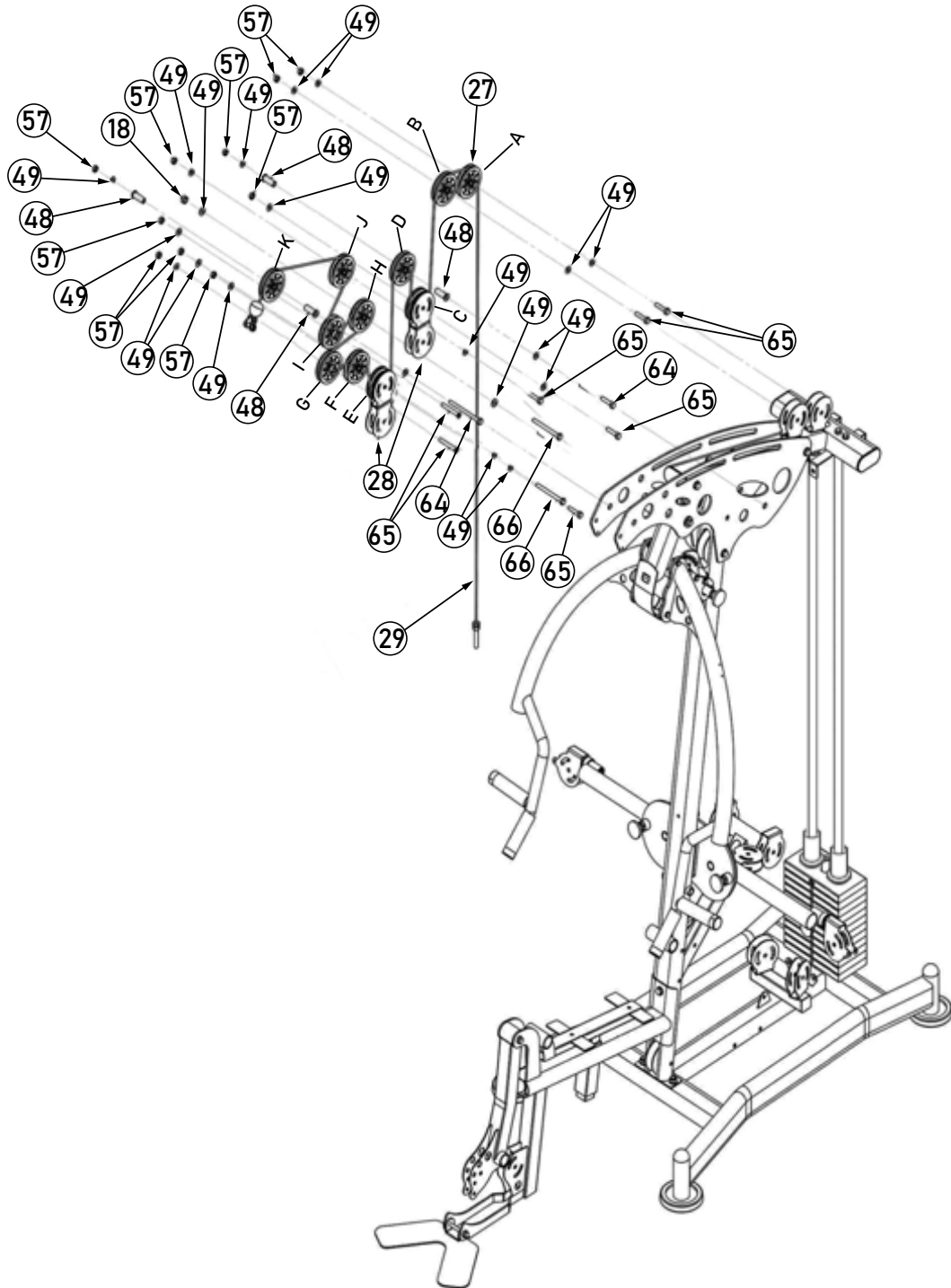

Cable (#29) = 166.5" (1 bolt end and one rubber ball end)

Installing Step 9 Gym Cable Wiring Diagram

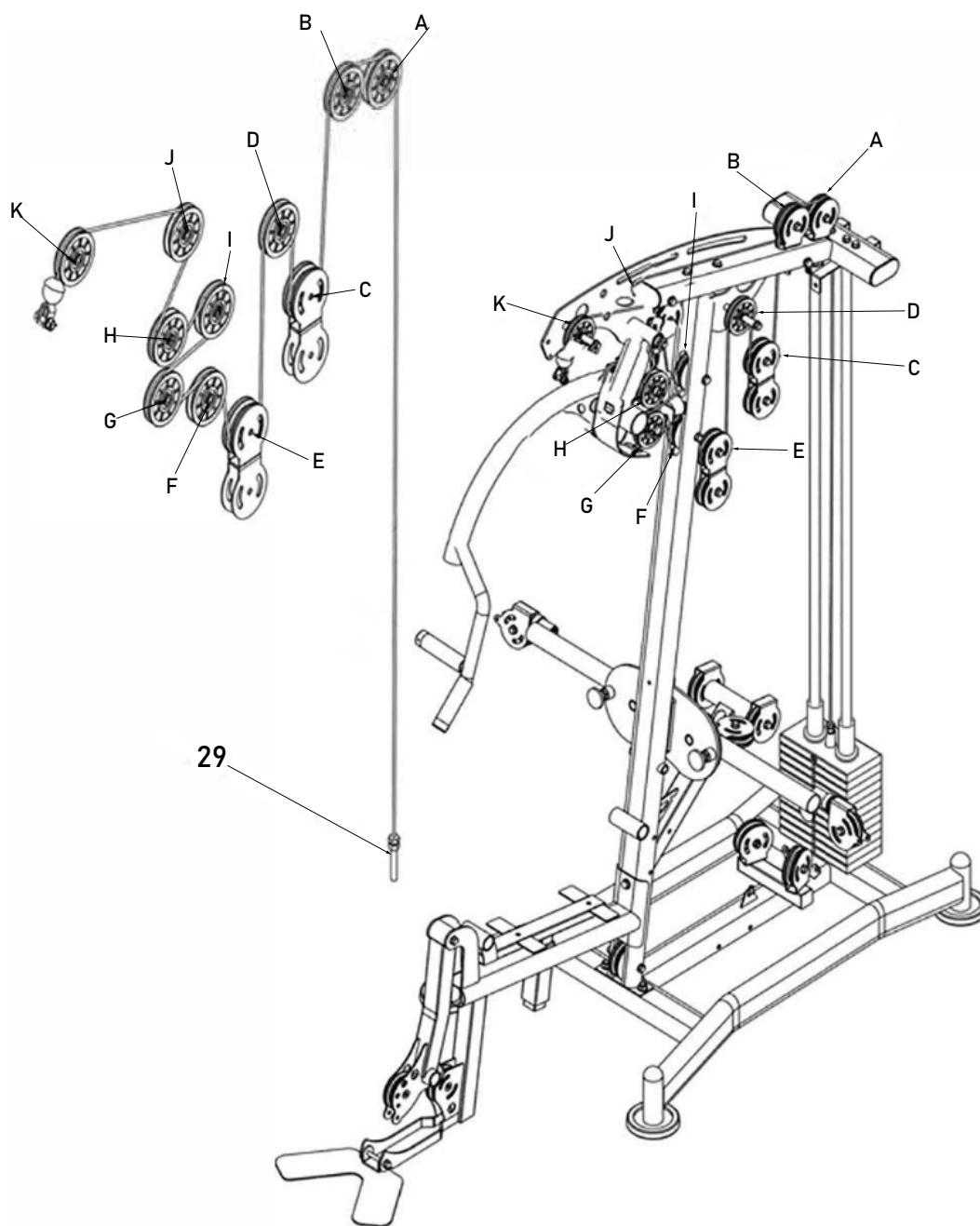

Cable (#29) = 166.5" (1 bolt end and one rubber ball end)

Installing Step 9 After Installation

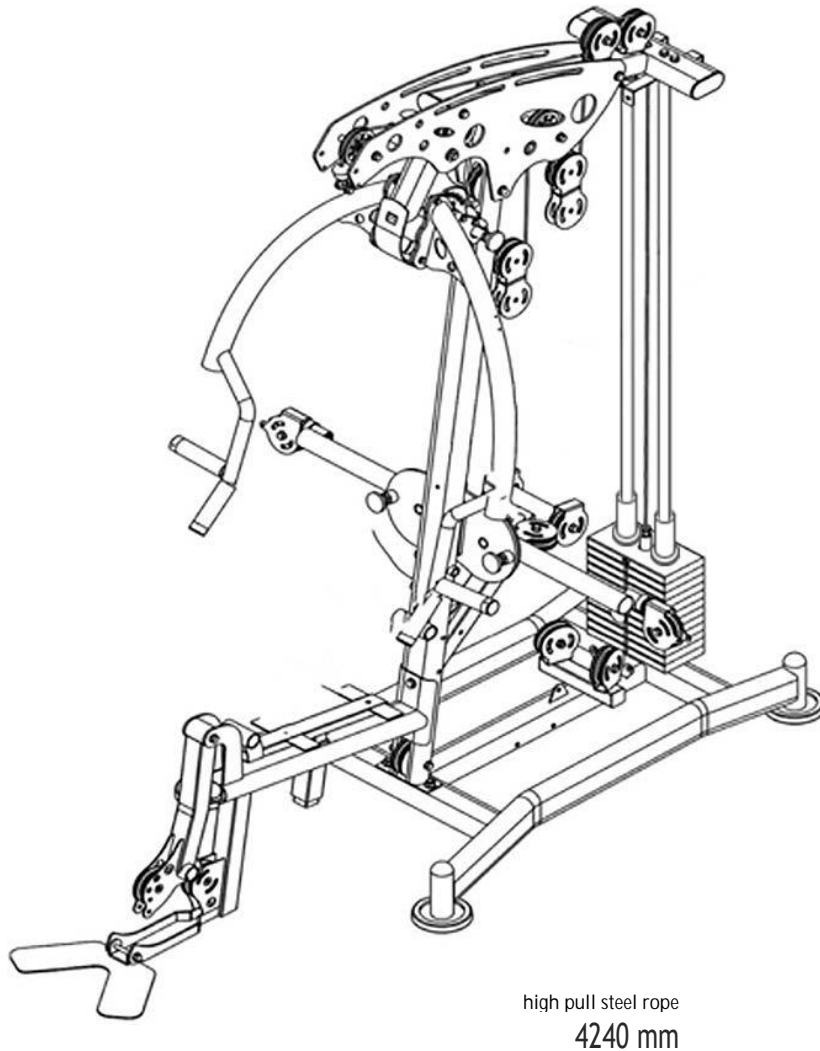

Installation Instruction

1. Fix the 5PCS pulley (27) at the five points A, B, C, E, J with M10*45 outer hexagonal bolts (65), Φ 10 washers (49), and M10 lock nuts (57).
2. Fix the 2PCS pulley (27) at two points D and K with M10*130 outer hexagonal bolts (64), pulley spacers (48), Φ 10 washers (49), and M10 locknuts (57).
3. Fasten the pulley (27) at point H with M10*130 outer hexagonal bolts (64), Φ 10 washers (49), and M10 lock nuts (57).
4. Fasten the pulley (27) to point F with M10*115 outer hexagonal bolts (66), Φ 10 washers (49), and M10 lock nuts (57).
5. Remove the end of the high pull Gym Cable (29) with the ball head.
6. Connect the end of the high pull Gym Cable (29) with the lifting rod, remove the end of the ball head from point A-K, and finally install the ball head of the Gym Cable.

Installing Step 10 Exploded View

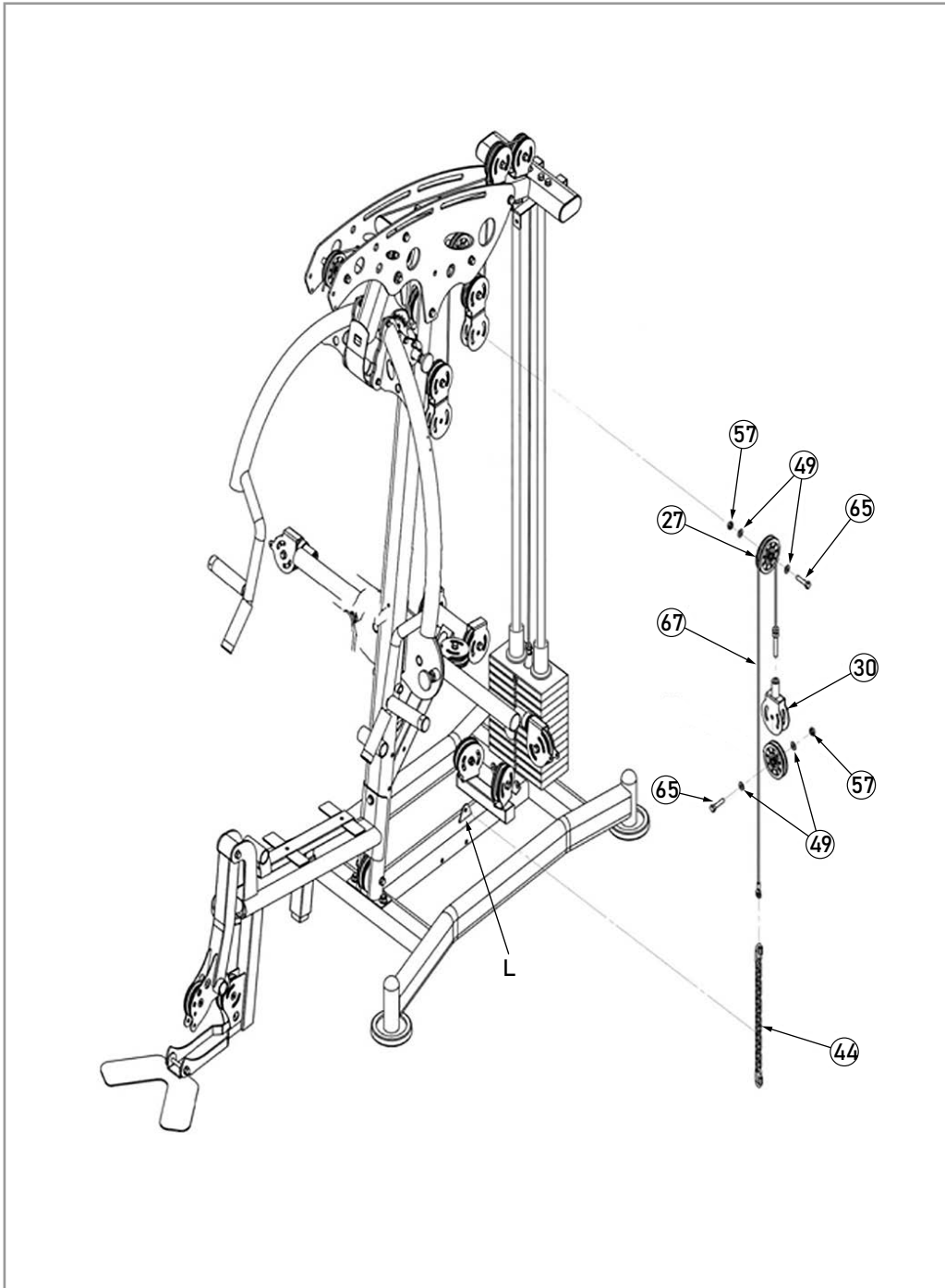

Cable (#67) = 57.5" (1 bolt end and 1 hole end)

Installing Step 10 After Installation

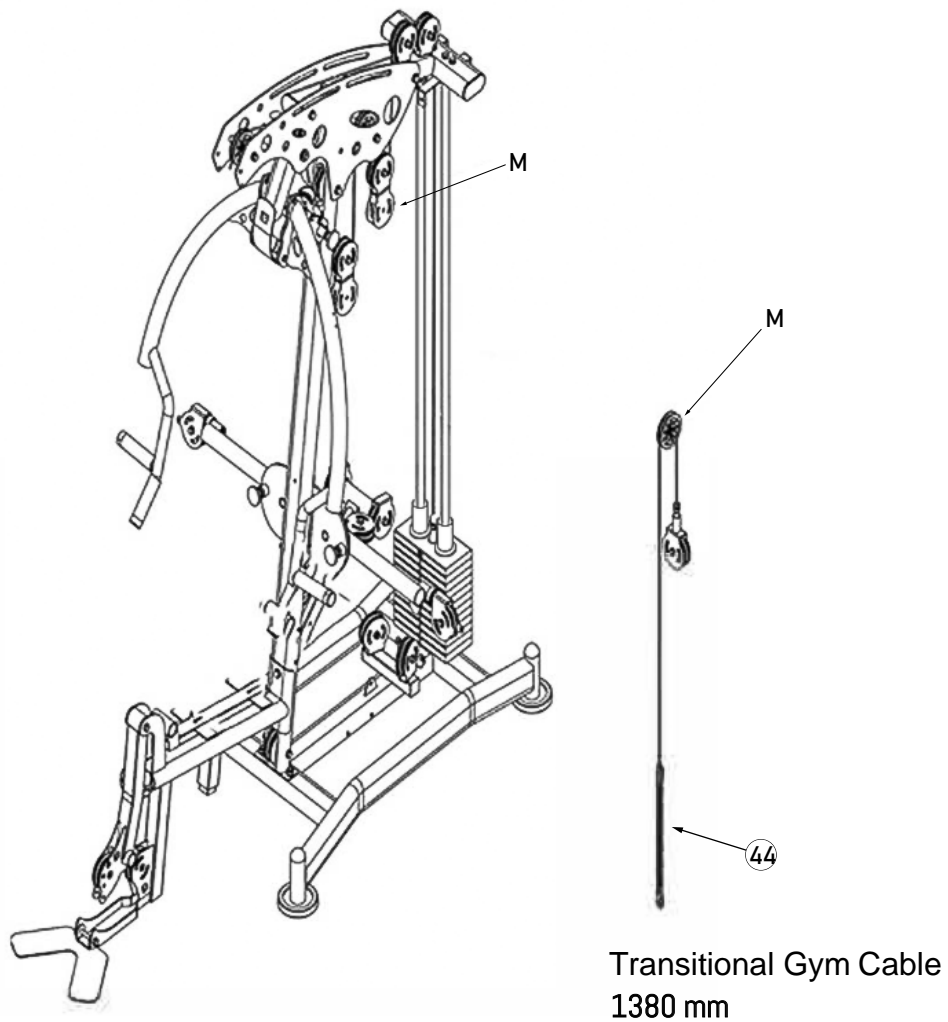

Cable (#67) =57.5" (1 bolt end and 1 hole end)

Installation Instruction

1. Connect one end of the quick link chain (44) to the transitional Gym Cable (67), and the other end of the quick link chain to the chasis weldment.
2. Connect the other end of the transitional Gym Cable (67) to the pulley piece (30)
3. Fasten 1PCS pulley (27) and transitional Gym Cable (67) at point L with M10*45 outer hexagonal bolts (65), Φ 10 washer (49) and M10 lock nut (57).

Note: The outer hexagonal bolts need to be tightened.

Installing Step 11 Exploded View

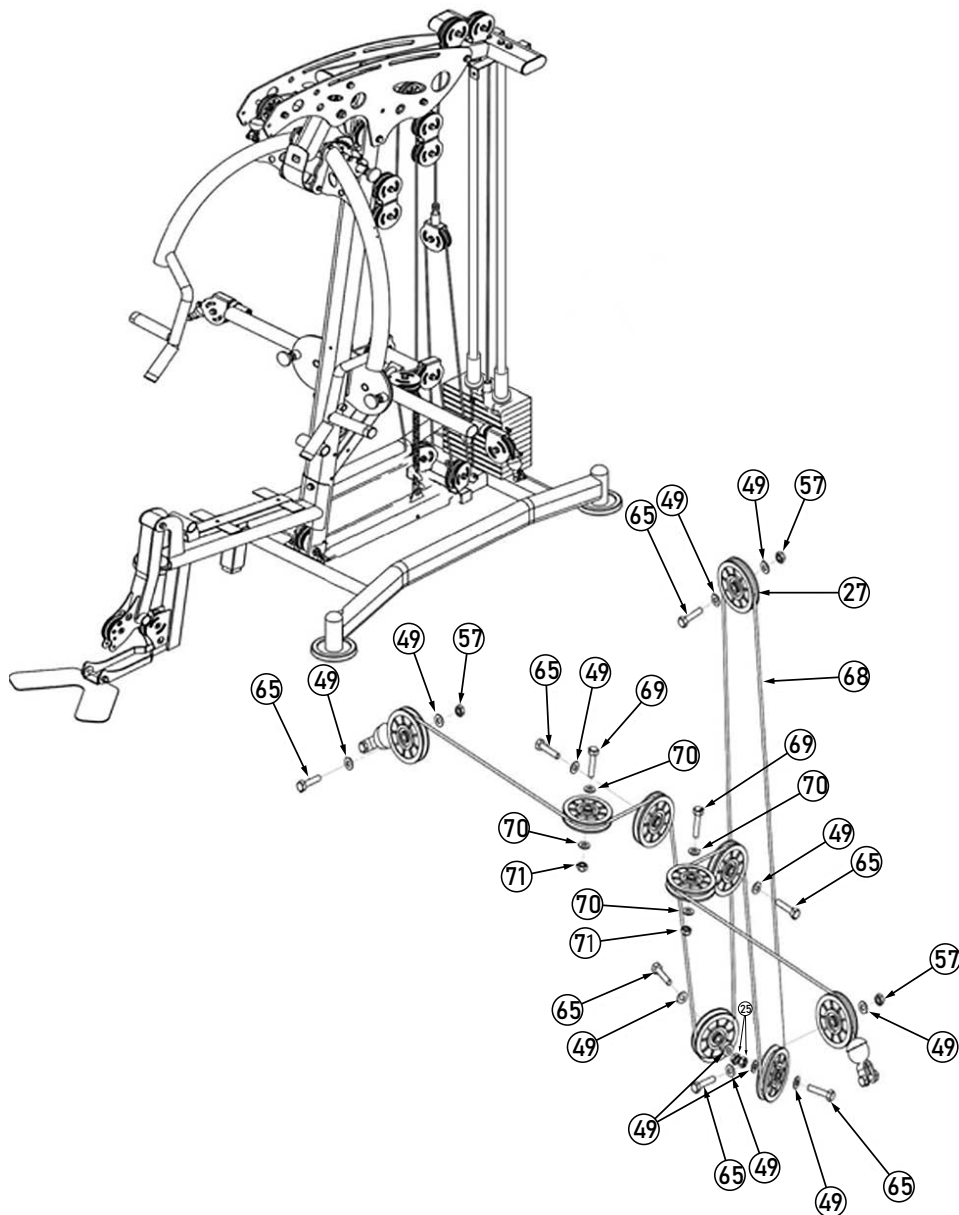

Cable (#68) = 203" (2 rubber ball ends)

Installing Step 11 Gym Cable Writing Diagram

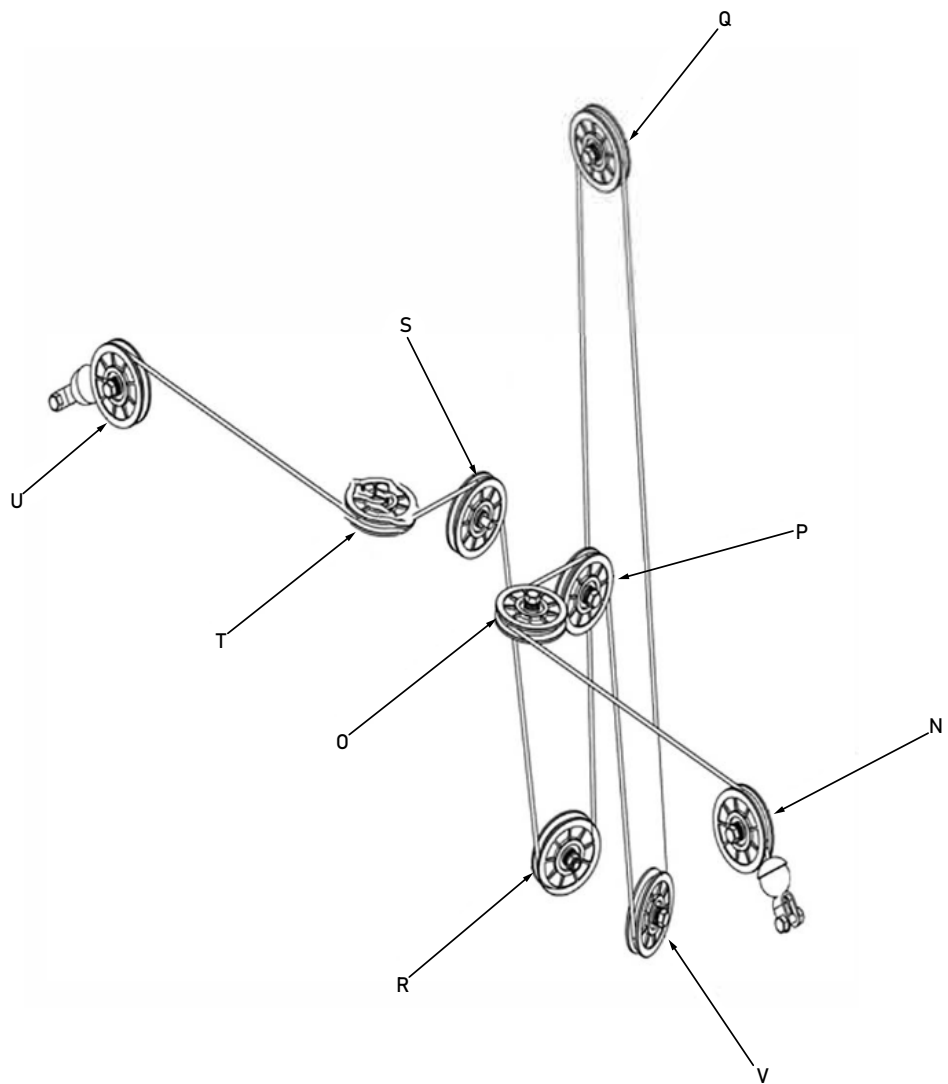

Cable (#68) = 203" (2 rubber ball ends)

Installing Step 11 After Installation

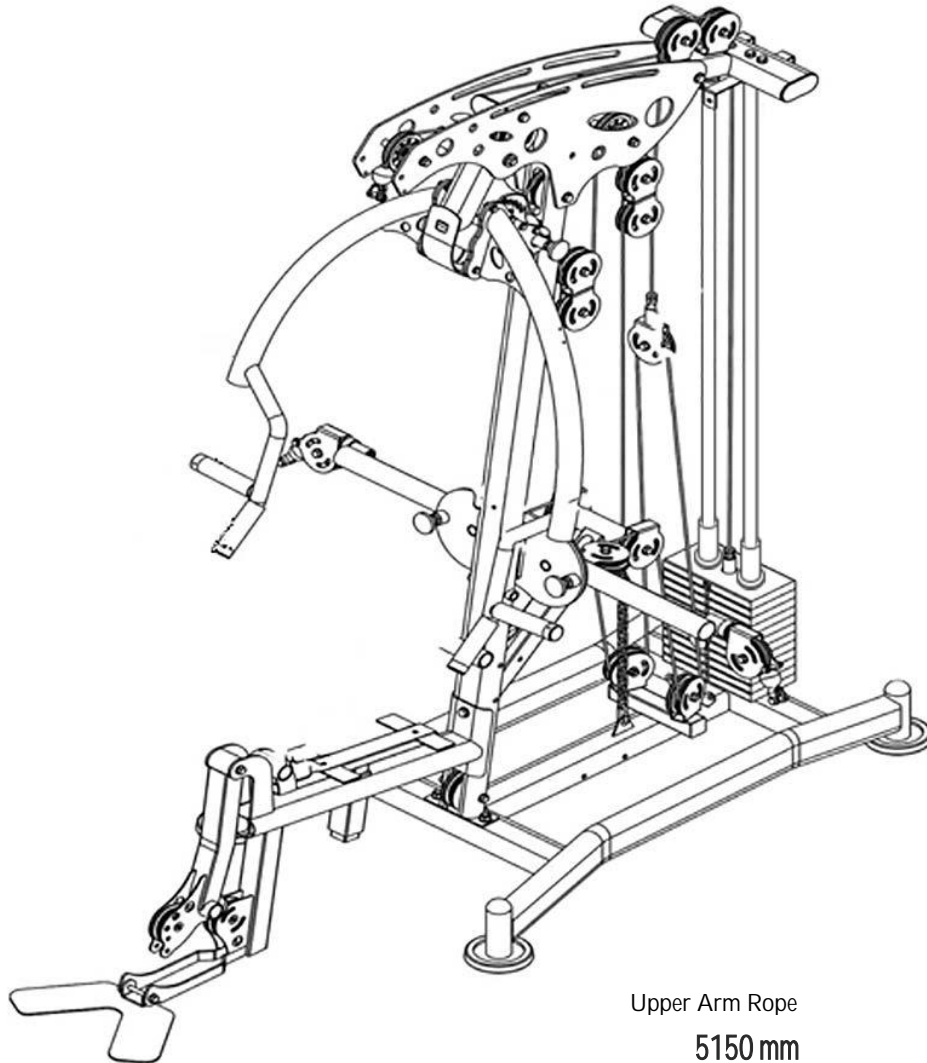

Upper Arm Rope
5150 mm

Installation Instruction

1. Fasten the 7PCS pulley (47) to points N, Q, R, T, U, V with M10*45 outer hexagonal bolts (65), $\Phi 10$ washers (49), and M10 lock nuts (57).
2. Fasten the 2PCS pulley at points P and S with M10*45 outer hexagonal bolts (65) and $\Phi 10$ washers (49).
3. Remove the end of the butterfly arm Gym Cable (68) with the ball head.
4. Pass the end of the butterfly arm Gym Cable (68) with the ball head taken off through points O, P, Q, R, S, T, U, V from point N, and then install the butterflyarm Gym Cable (68) ball head.
5. Install M8*45 outer hexagonal bolts (69), $\Phi 8$ washers (70), M8 lock nuts (71) on points N and T of the wheel frame.

Note: The outer hexagonal bolts need to be tightened.

Installing Step 12 Exploded View

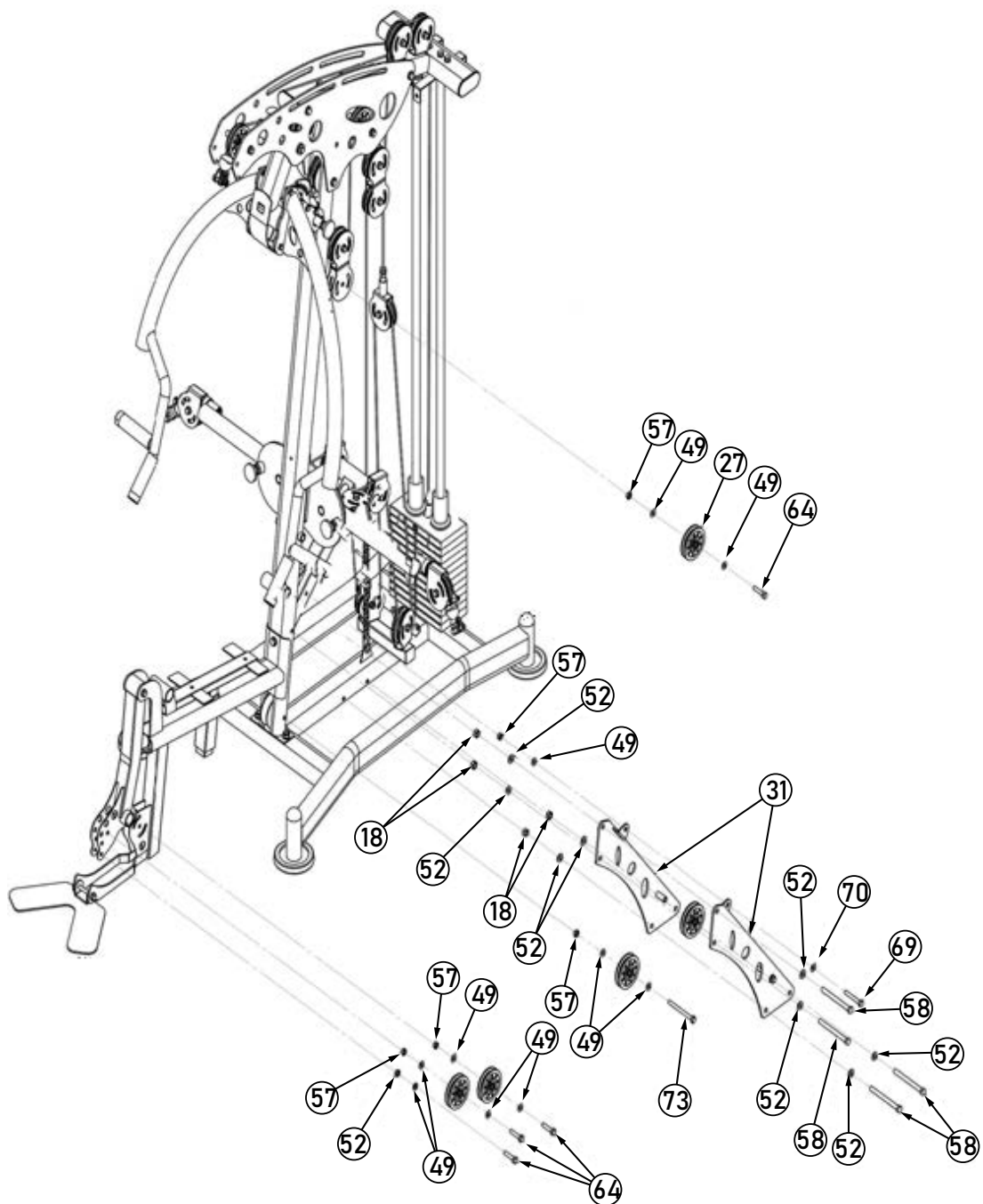

Installing Step 12 After Installation

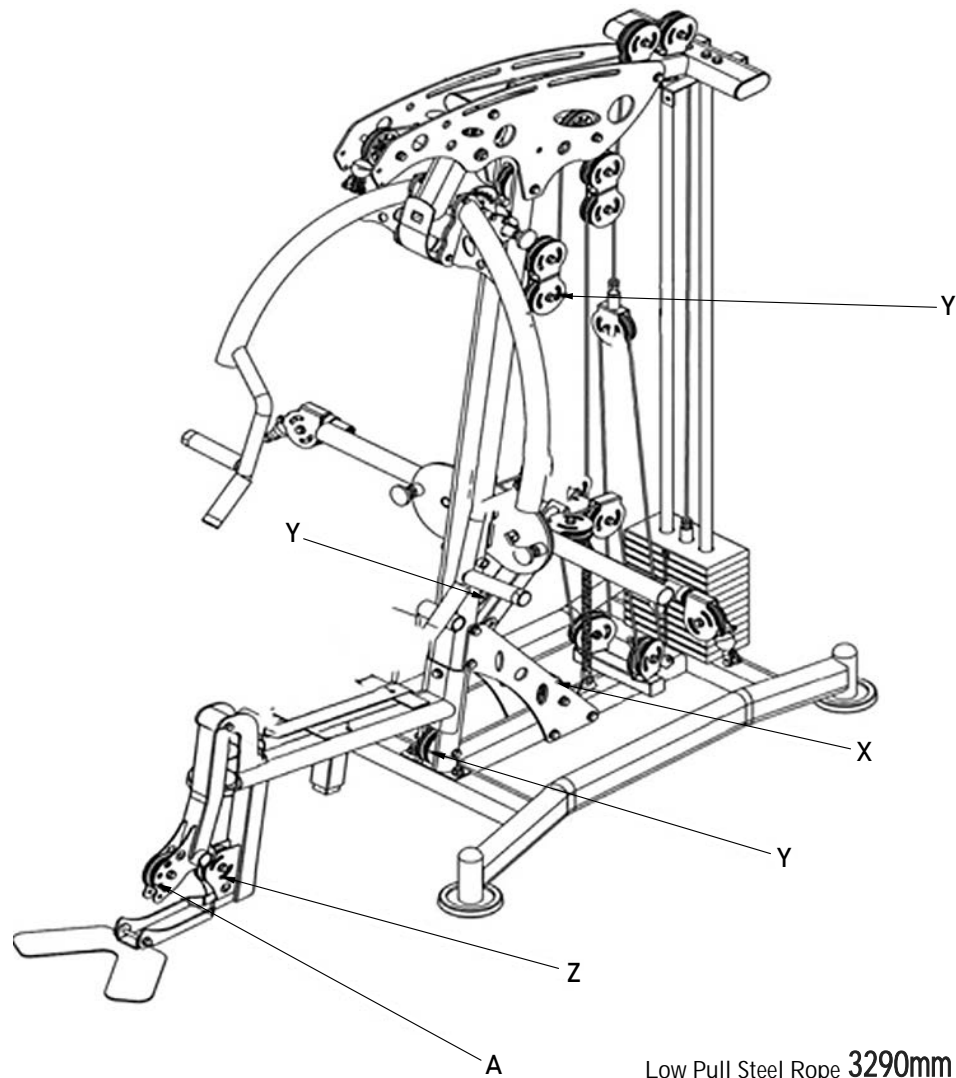

Installation Instruction

1. Fasten M12*130 outer hexagonal bolts (58), Φ 12 washers (52), M12 lock nuts (53), inclined support board (31) to the inclined support beam and the chassis.
2. Use M10*70 outer hexagonal bolts (72), Φ 10 washers (49), M10 lock nuts (57) to connect with inclined support board (31), inclined support pulley frame (11), inclined support board-right (31).
3. Fix 1 PCS pulley (27) at point X with M10*130 outer hexagonal bolts (64), Φ 10 washers, M10 lock nuts (57).
4. Fix 1PCS pulley (27) at point Y with M10*110 outer hexagonal bolts (73), Φ washer (49), and M10 lock nut (57).
5. Fasten the wheel board at A1 with M8*45 outer hexagonal bolts (69), Φ 8 washer (70), and Φ M8 lock nut (71).

Note: The outer hexagonal bolts need to be tightened.

Installing Step 13 Gym Cable Writing Diagram

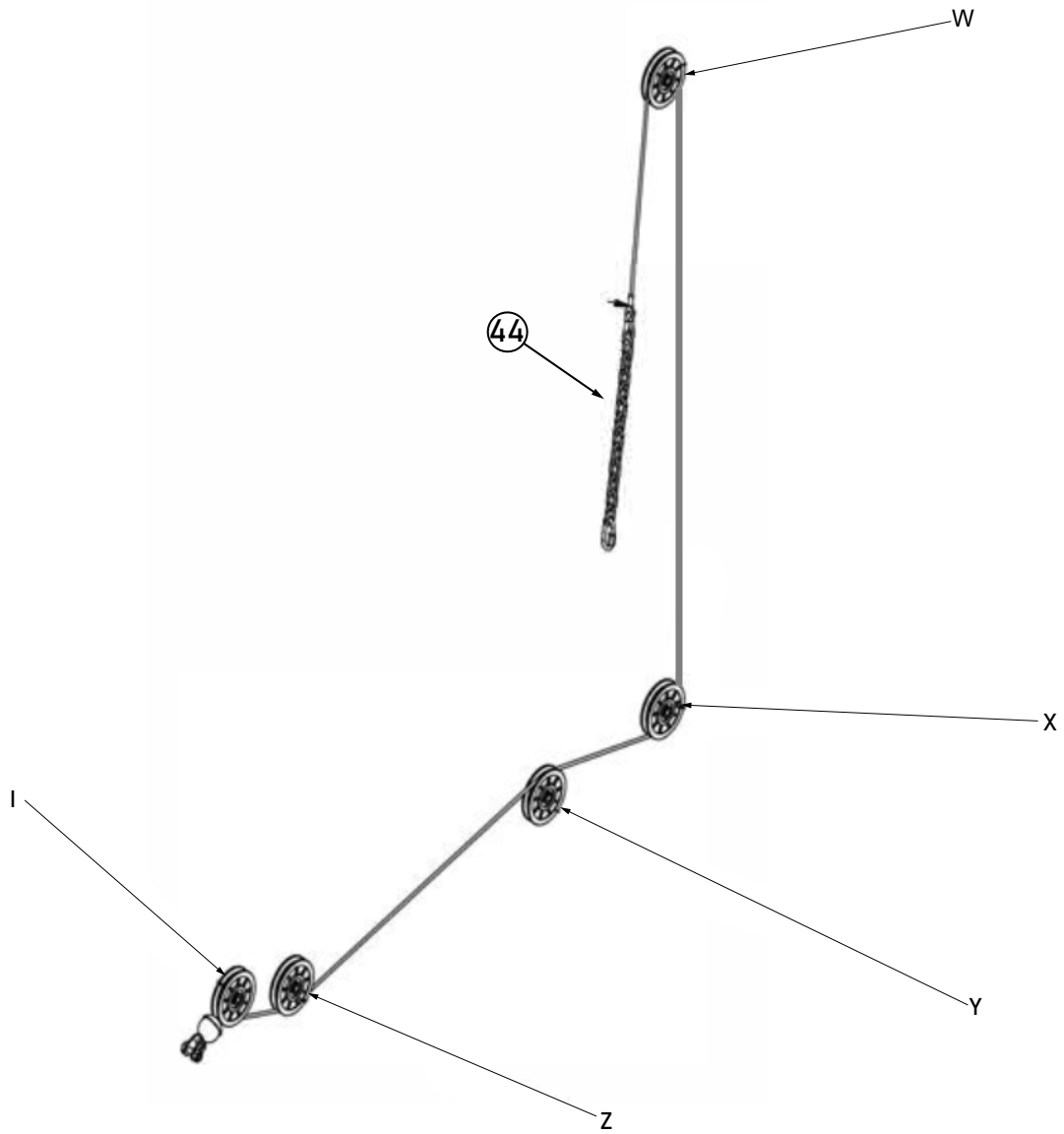

Installing Step 13 Exploded View

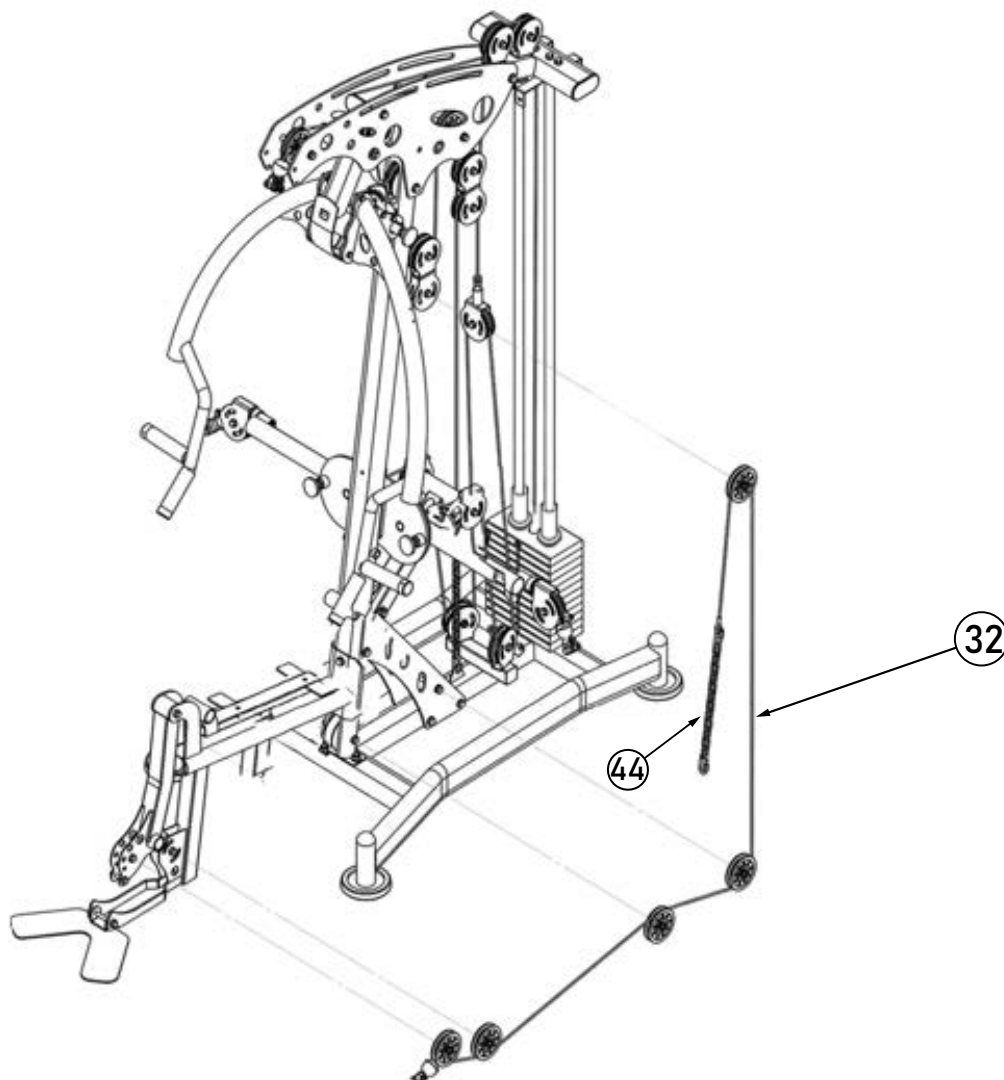

Cable (#32) = 130" (1 hole end and one rubber ball end)

Installation Instruction

1. Remove the end of the low pull Gym Cable (32) with the ball head.
2. Pass the end of the low pull Gym Cable (32) with ball head taken off from the six points W, X, Y, Z, A1, and then install the removed ball head on the low pull Gym Cable.

Installing Step 14 Exploded View

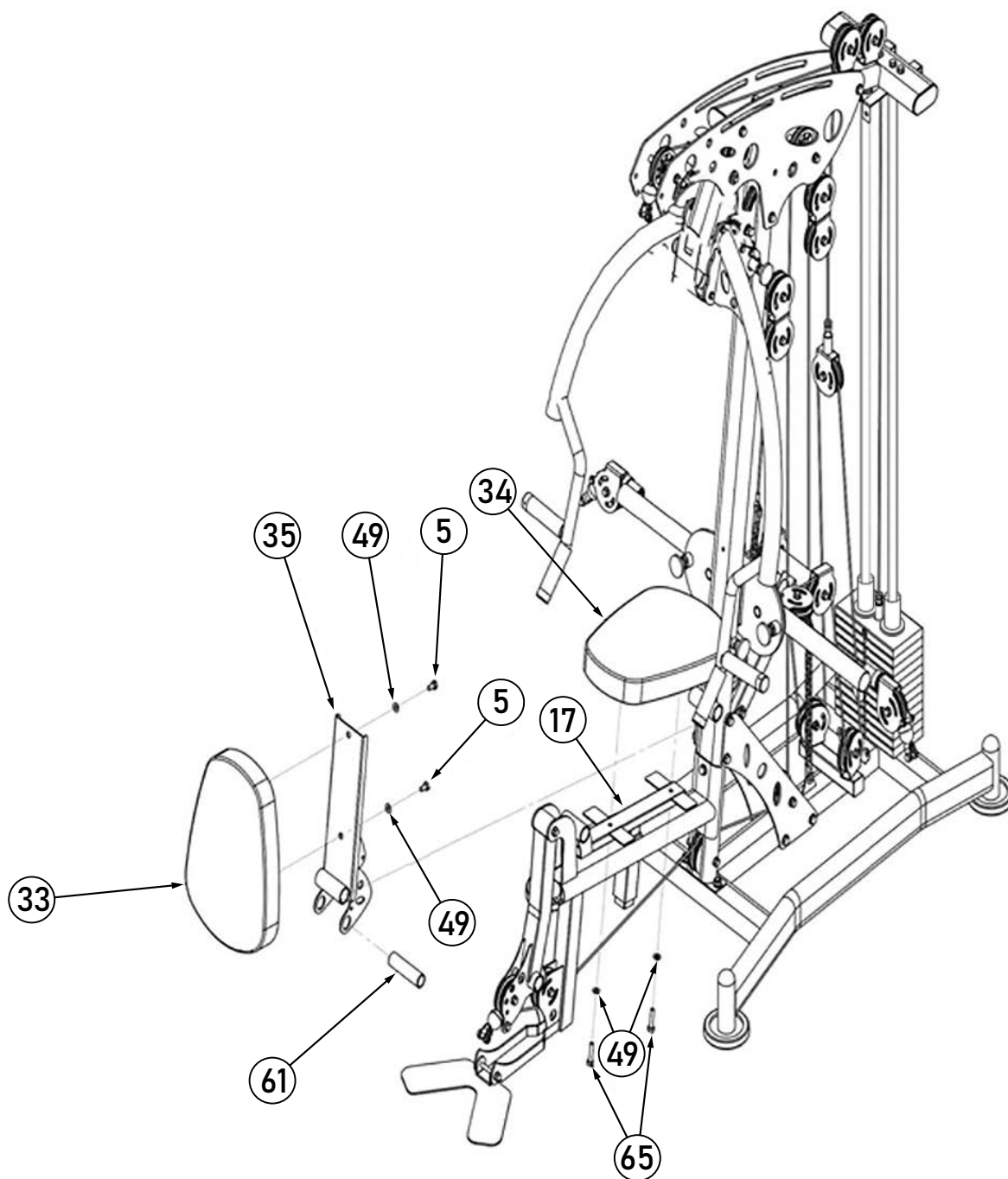

Installing Step 14 After Installation

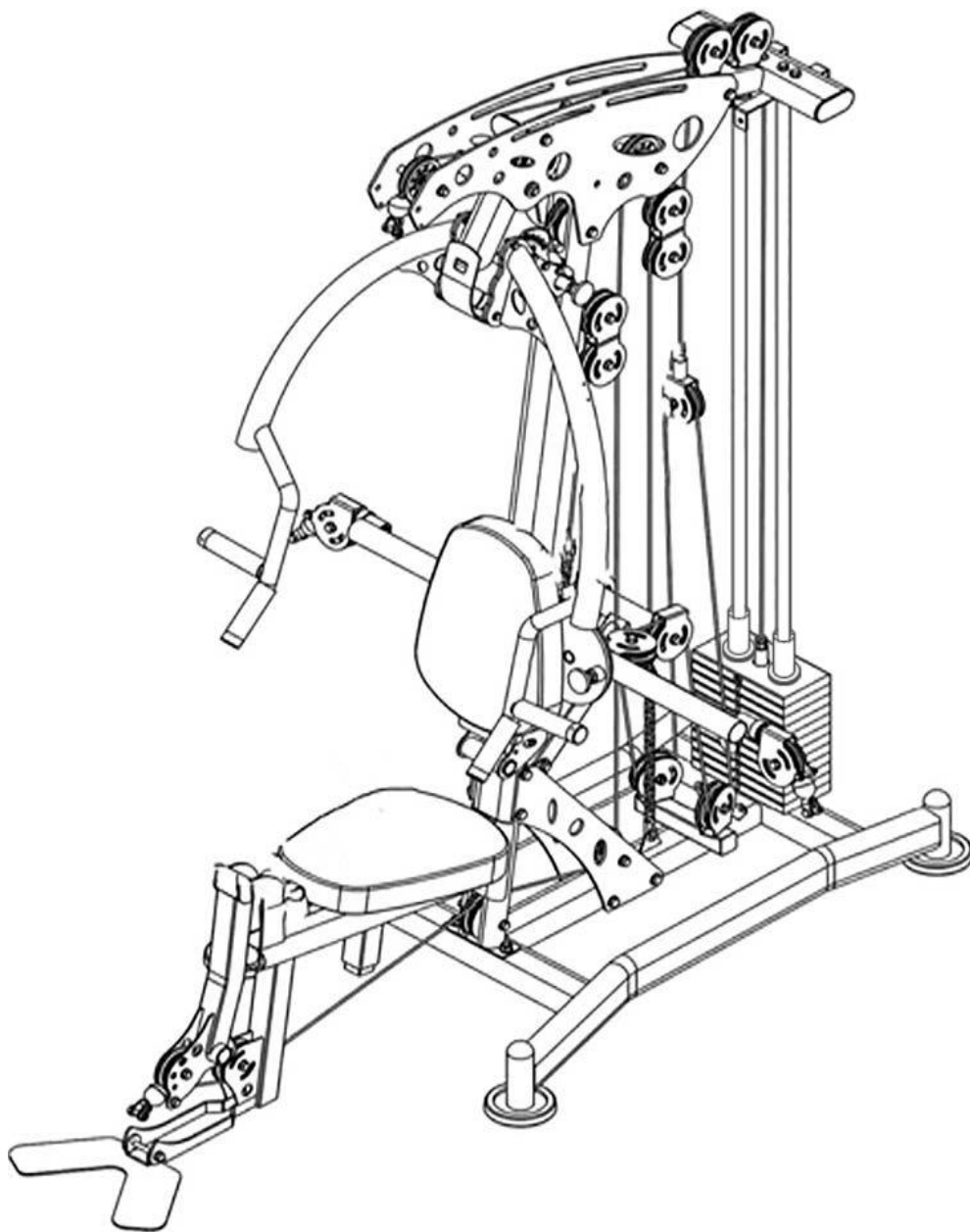

Installation Instruction

1. Fasten the backrest cushion (33) on the backrest adjusting board (35) with M10*20 outer hexagonal bolts (5) and Φ 10 washer (49).
2. Fasten the seat cushion (34) on the seat adjustment tube (17) with M10*45 outer hexagonal bolts (65) and Φ 10 washer (49).
3. Use the backrest tube shaft (61) to fix the backrest adjustment board (35) on the inclined support beam.

Installing Step 15 Exploded View

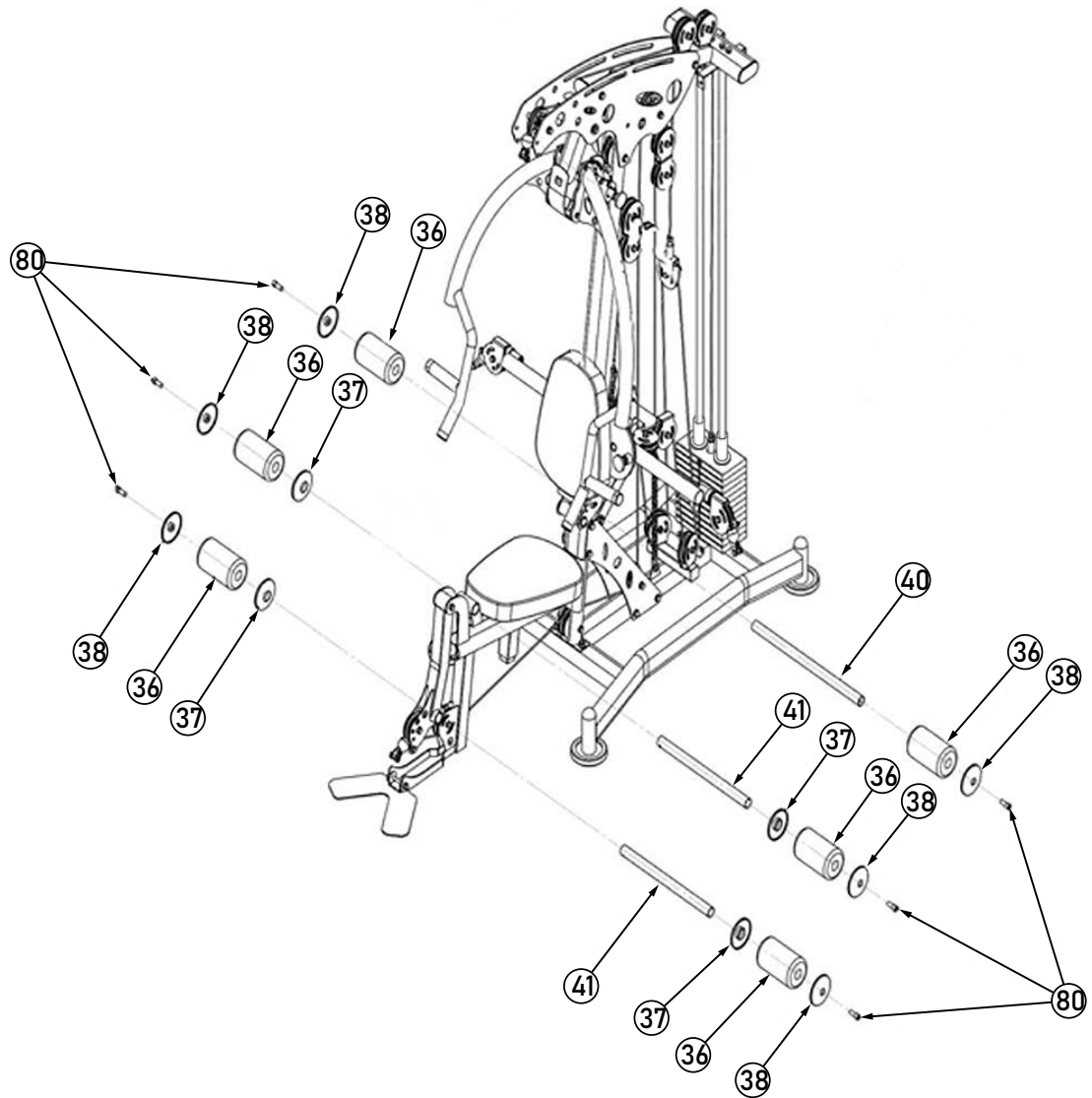

Installing Step 15 After Installation

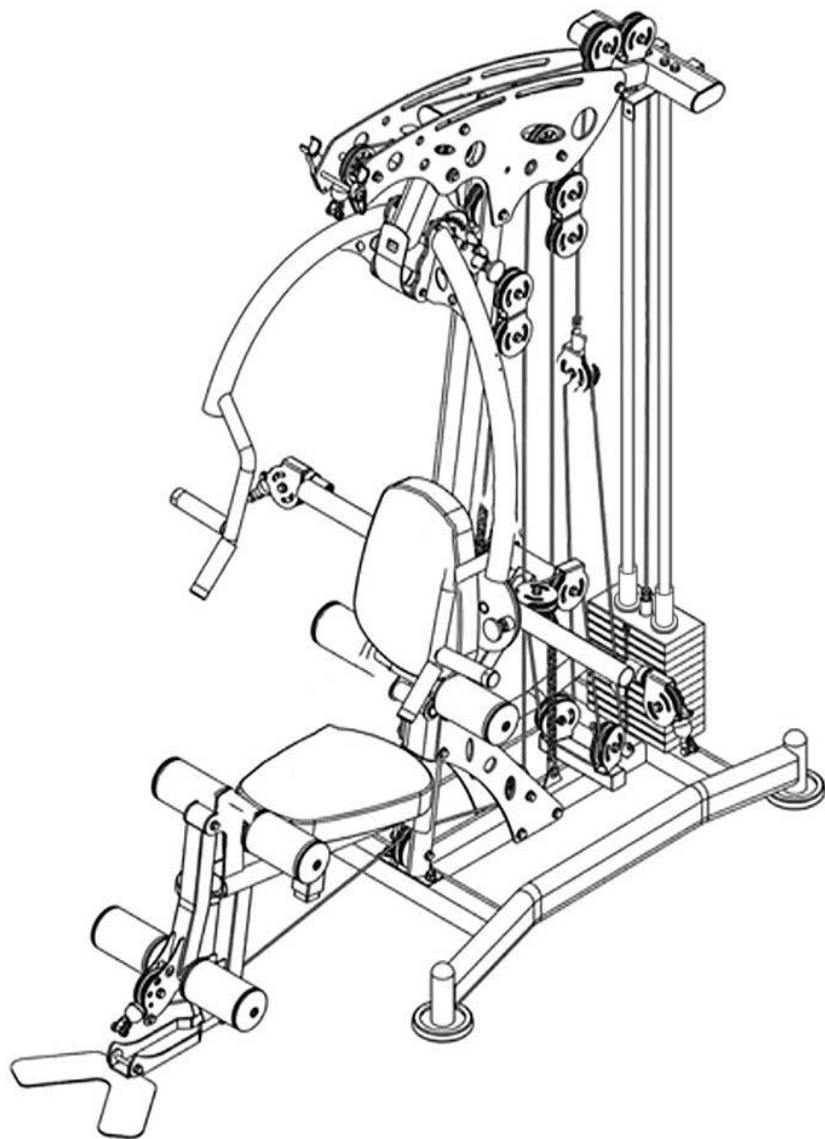

Installation Instruction

1. Insert the foam rod (40) into the backrest adjustment frame, and put the foam inner end cap (37), foam (36), and foam outer end cap (38) in sequence at both ends of the foam rod (40).
2. Connect the foam tube (41) onto the seat cushion adjusting frame and the foot hook bending tube, and put the foam inner end cap (37), foam (36), foam outer end cap (38) in sequence at both ends of the foam tube (41).

Installing Step 16 Exploded View

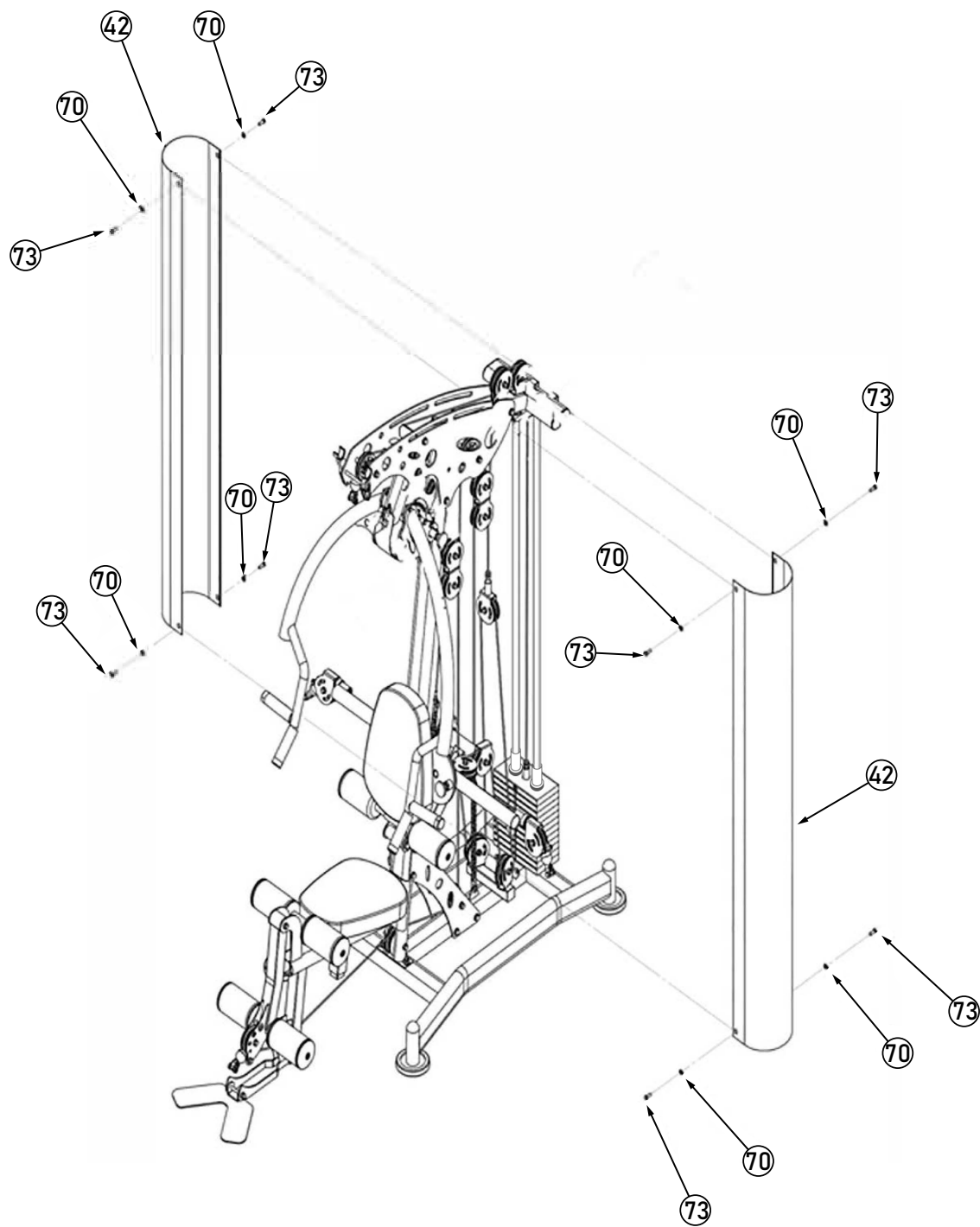

Installing Step 16 After Installation

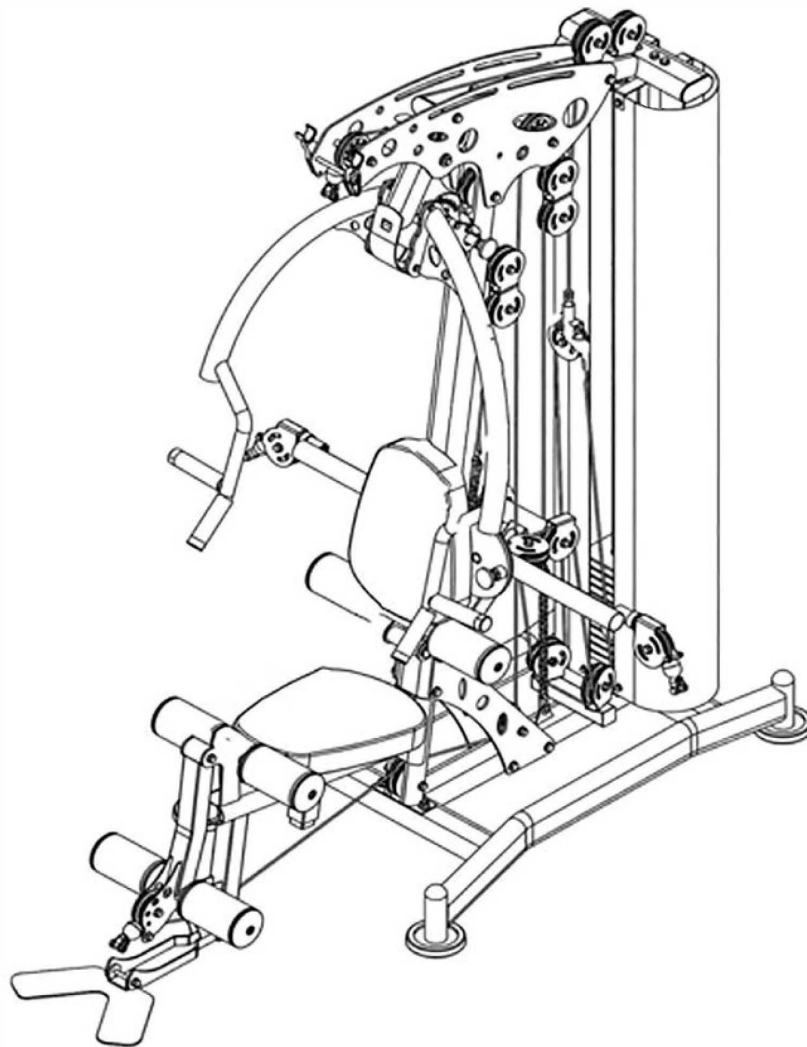

Installation Instruction

1. Fasten the shield (42) on the shield support frame and the chasis shield fixing piece with M8*16 outer hexagonal bolt (73) and $\Phi 8$ washer (70).

Note: The outer hexagonal bolts need to be tightened.

Installing Step 17 Exploded View

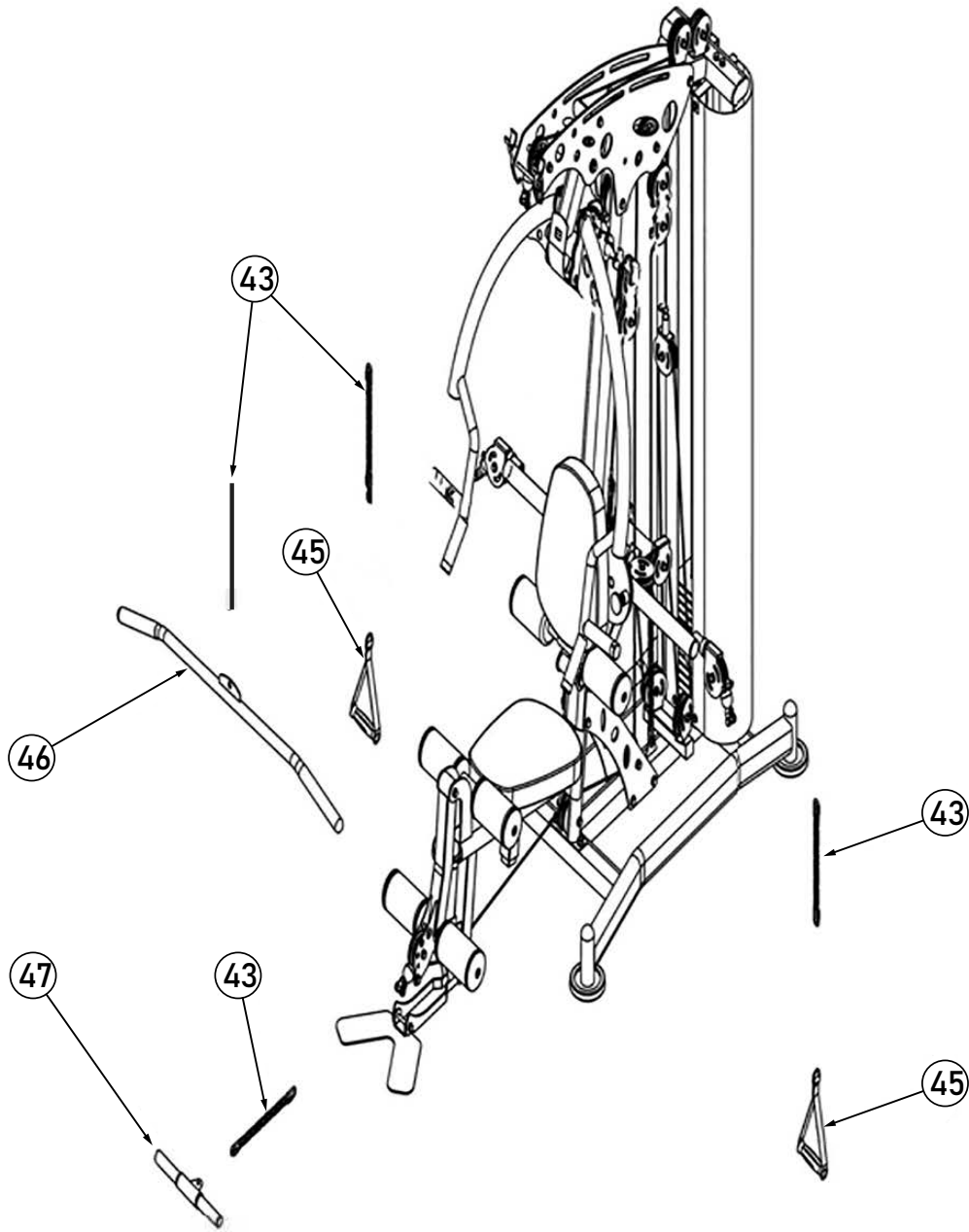

Installing Step 17 After Installation

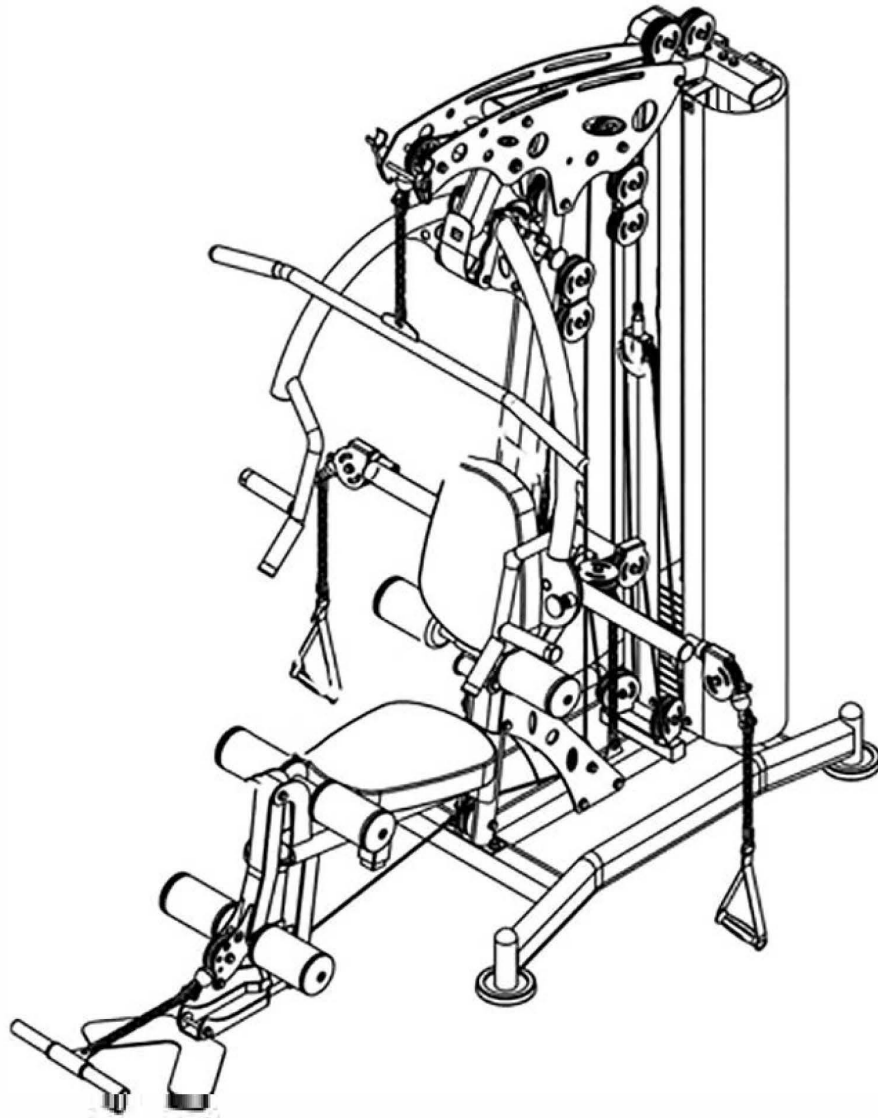

Installation Instruction

1. Connect the 9-link chain+quick-connect ring (43) to the pull strap (45), and then connect the other end of the 9-link chain ring (43) to the ball end of the butterfly arm steel rope.
2. Connect the 9-link chain+quick-connect ring (43) to the high pull rod (47), and then connect the other end of the 9-link chain quick connect ring (43) to the ball end of the high pull Gym Cable

Note: Check whether the bolts, lock nuts, and torx pull pins of the whole machine are tightened. They can only be used after tightening.

MAINTENANCE + FINAL ASSEMBLY CHECK: CABLE ADJUSTMENTS

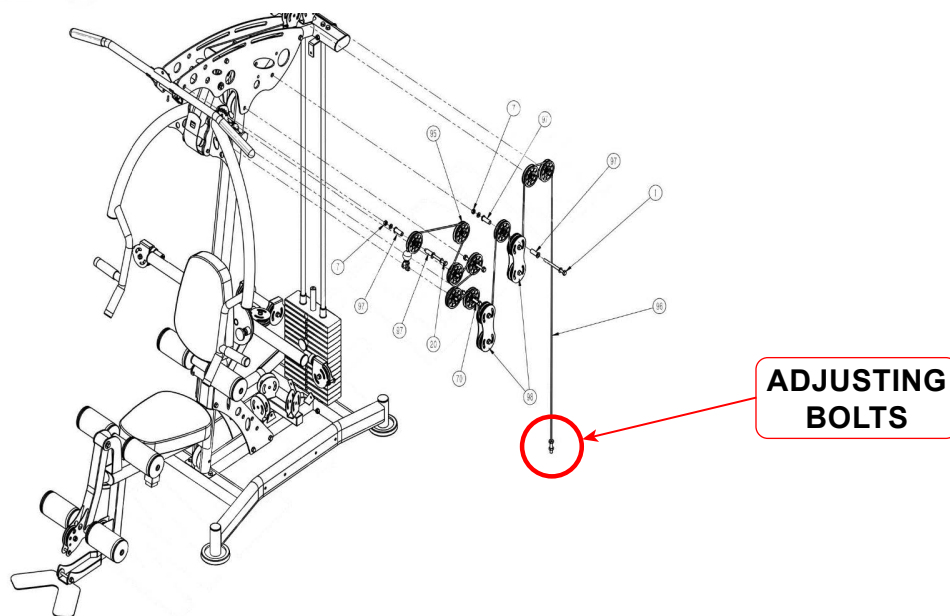
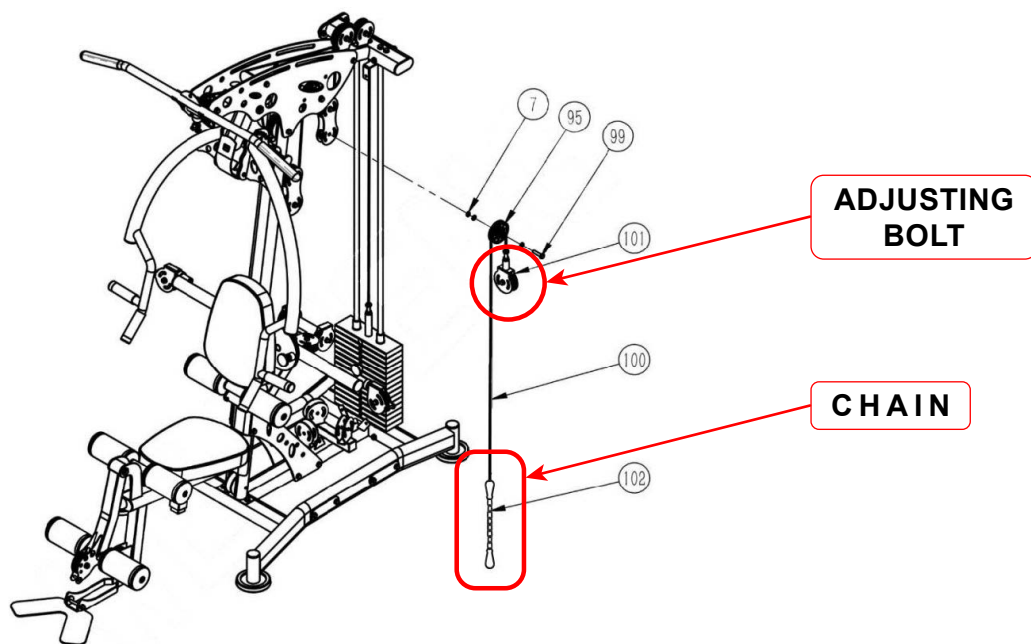

The cables should be installed firm and without loose tension, but not too tight. If the cables are skipping, or don't glide properly, then it is likely because the cables are not installed correctly, and need to be adjusted. Note also that they can loosen over time as cables naturally stretch, and might need to be tightened should they loosen up in the future. Note the various areas to tighten.

- 1) Chain: The chain is meant to be adjusted by adjusting the links to be shorter or longer, and putting the right length into the carabiner. If the cables are very loose, this should be the first thing checked, as the chain is to make large adjustments. The "Adjusting Bolts" are to make small adjustments
- 2) Adjusting Bolts: These are used to make small adjustments. Just tighten until they feel firm, as mention above, using an adjustable wrench (see pic). There are 5 different cables on the machine, so each adjustment will only effect one cable, so, just be aware of that
- 3) If the tension doesn't fix the smoothness, then something might be obstructing the cable path, or the cable could be torn. In this, send pics of the cable routing and effected areas and our tech support can assist.